

# 3GPP TS 23.002 V15.0.0 (2018-03)

---

*Technical Specification*

## **3rd Generation Partnership Project; Technical Specification Group Services and System Aspects; Network architecture (Release 15)**



The present document has been developed within the 3rd Generation Partnership Project (3GPP™) and may be further elaborated for the purposes of 3GPP. The present document has not been subject to any approval process by the 3GPP Organisational Partners and shall not be implemented. This Specification is provided for future development work within 3GPP only. The Organisational Partners accept no liability for any use of this Specification. Specifications and reports for implementation of the 3GPP™ system should be obtained via the 3GPP Organisational Partners' Publications Offices.

Keywords

---

LTE, GSM, UMTS, network, architecture

**3GPP**

Postal address

---

F-06921 Sophia Antipolis Cedex - FRANCE

Office address

---

650 Route des Lucioles - Sophia Antipolis  
Valbonne - FRANCE  
Tel.: +33 4 92 94 42 00 Fax: +33 4 93 65 47 16

Internet

---

<http://www.3gpp.org>

---

**Copyright Notification**

No part may be reproduced except as authorized by written permission.  
The copyright and the foregoing restriction extend to reproduction in all media.

© 2018, 3GPP Organizational Partners (ARIB, ATIS, CCSA, ETSI, TSDSI, TTA, TTC).  
All rights reserved.

UMTS™ is a Trade Mark of ETSI registered for the benefit of its members  
3GPP™ is a Trade Mark of ETSI registered for the benefit of its Members and of the 3GPP Organizational Partners  
LTE™ is a Trade Mark of ETSI registered for the benefit of its Members and of the 3GPP Organizational Partners  
GSM® and the GSM logo are registered and owned by the GSM Association

# Contents

Foreword .....	12
Introduction .....	12
1 Scope .....	13
2 References .....	13
3 Definitions and abbreviations .....	19
3.1 Public Land Mobile Network (PLMN).....	19
3.2 Core Network (CN) and Access Network (AN) .....	19
3.3 Circuit Switched (CS) and Packet Switched (PS) Domains.....	19
3.3.1 CS Domain.....	20
3.3.2 PS Domain .....	20
3.3a IP Multimedia subsystem (IMS).....	20
3.4 Location register .....	20
3.5 Cell.....	21
3.6 Base Station Controller (BSC) area.....	21
3.7 Radio Network Controller (RNC) area.....	21
3.8 Location Area (LA).....	21
3.9 Routing Area (RA).....	21
3.9a Tracking Area (TA).....	21
3.10 MSC area.....	21
3.11 VLR area .....	21
3.12 SGSN area .....	22
3.13 Zones for Regional Subscription.....	22
3.14 Service area .....	22
3.15 Group call area.....	22
3.15a MME Area.....	22
3.16 Pool-area .....	22
3.17 Serving GW Service Area .....	22
4 The basic entities of the mobile system .....	23
4.1 The Core Network (CN) entities .....	23
4.1.1 Entities common to the PS and CS domains .....	23
4.1.1.1 The Home Subscriber Server (HSS).....	23
4.1.1.1.1 The Home Location Register (HLR) .....	24
4.1.1.1.2 The Authentication Centre (AuC).....	24
4.1.1.1.3 HSS logical functions.....	25
4.1.1.2 The Visitor Location Register (VLR) .....	26
4.1.1.3 (void).....	27
4.1.1.4 The Equipment Identity Register (EIR).....	27
4.1.1.5 SMS Gateway MSC (SMS-GMSC) .....	27
4.1.1.6 SMS Interworking MSC (SMS-IW MSC).....	27
4.1.1.7 Subscription Locator Function (SLF).....	27
4.1.2 Entities of the CS domain .....	28
4.1.2.1 The Mobile-services Switching Centre (MSC) .....	28
4.1.2.1.1 MSC Server .....	28
4.1.2.1.2 Circuit Switched - Media Gateway Function (CS-MGW).....	29
4.1.2.2 The Gateway MSC (GMSC).....	29
4.1.2.2.1 Gateway MSC Server (GMSC Server).....	29
4.1.2.3 The Interworking Function (IWF).....	29
4.1.3 Entities of the GPRS PS domain.....	30
4.1.3.1 Serving GPRS Support Node (SGSN).....	30
4.1.3.2 Gateway GPRS Support Node (GGSN).....	30
4.1.3.3 Void.....	31
4.1.4 Entities of the EPC PS Domain .....	31

4.1.4.1	MME .....	31
4.1.4.2	Gateways .....	32
4.1.4.2.1	Serving GW .....	32
4.1.4.2.2	PDN GW .....	32
4.1.4.2.3	Local GW (L-GW).....	33
4.1.4.3	SGSN.....	33
4.1.4.4	Trusted and Untrusted Non-3GPP Access Network.....	33
4.1.4.5	ePDG .....	34
4.1.4.6	3GPP AAA Server .....	34
4.1.4.7	3GPP AAA Proxy .....	34
4.1.4.8	ANDSF.....	34
4.1.5	Border Gateway (BG)].....	35
4.2	The Access Network (AN) entities .....	35
4.2.1	The Base Station System (BSS) .....	35
4.2.1.1	Base Station Controller (BSC) .....	35
4.2.1.2	Base Transceiver Station (BTS).....	36
4.2.2	The Radio Network System (RNS).....	36
4.2.2.1	Radio Network Controller (RNC) .....	36
4.2.2.2	Node B.....	36
4.2.3	Access Network elements for E-UTRAN .....	36
4.2.3.1	E-UTRAN Node B (eNB).....	36
4.2.3.2	Evolved UTRAN.....	36
4.3	The Mobile Station (MS).....	36
4.4	User Equipment (UE).....	37
4a	The specific entities of the 3GPP system .....	37
4a.1	The Group Call Register (GCR) entity.....	37
4a.2	(void).....	38
4a.3	The Location Services (LCS) entities.....	38
4a.3.1	Location Services (LCS) entities in RAN .....	38
4a.3.2	Gateway Mobile Location Centre (GMLC) .....	39
4a.3.3	Location Measurement Unit (LMU) .....	39
4a.3.4	Evolved Serving Mobile Location Centre (E-SMLC).....	39
4a.4	CAMEL entities.....	40
4a.4.1	GSM Service Control Function (gsmSCF).....	40
4a.4.2	GSM Service Switching Function (gsmSSF) .....	40
4a.4.3	GSM Specialised Resource Function (gsmSRF) .....	40
4a.4.4	GPRS Service Switching Function (gprsSSF).....	40
4a.5	CBS-specific entities .....	40
4a.5.1	Cell Broadcast Centre (CBC) .....	40
4a.6	Number Portability Specific entities .....	40
4a.6.1	IN-based solution: Number Portability Database (NPDB).....	40
4a.6.2	Signalling Relay-based solution: Mobile Number Portability/Signalling Relay function (MNP-SRF) .....	41
4a.7	IP Multimedia (IM) Core Network (CN) Subsystem entities .....	41
4a.7.1	Call Session Control Function (CSCF) .....	41
4a.7.2	Media Gateway Control Function (MGCF) .....	41
4a.7.3	IP Multimedia Subsystem - Media Gateway Function (IMS-MGW).....	41
4a.7.4	Multimedia Resource Function Controller (MRFC) .....	42
4a.7.4a	Multimedia Resource Function Processor (MRFP) .....	42
4a.7.4b	Media Resource Broker (MRB).....	42
4a.7.5	Void .....	42
4a.7.6	Breakout Gateway Control Function (BGCF) .....	42
4a.7.7	Application Server (AS).....	43
4a.7.8	Interconnection Border Control Function (IBCF).....	43
4a.7.9	Transition Gateway (TrGW) .....	43
4a.7.10	Location Retrieval Function (LRF).....	43
4a.7.11	Service Centralization and Continuity Application Server (SCC AS) .....	44
4a.7.11a	Emergency Access Transfer Function (EATF).....	44
4a.7.12	Access Transfer Control Function (ATCF) .....	44
4a.7.13	Access Transfer Gateway (ATGW).....	44
4a.8	Signalling Gateway Function (SGW).....	44
4a.9	Global Text Telephony Specific entities .....	44

4a.10	Security Gateway (SEG) .....	44
4a.11	Application Function (AF) .....	45
4a.12	Void .....	45
4a.13	3GPP/WLAN Interworking entities .....	45
4a.13.1	WLAN UE .....	45
4a.13.2	3GPP AAA Proxy.....	45
4a.13.3	3GPP AAA Server.....	45
4a.13.4	WLAN Access Gateway (WAG).....	45
4a.13.5	Packet Data Gateway (PDG).....	45
4a.13.6	Home Agent (HA) .....	45
4a.14	Multimedia Broadcast Multicast Service (MBMS) specific entities .....	45
4a.14.1	General.....	45
4a.14.2	Broadcast-Multicast Service Centre (BM-SC) .....	46
4a.14.3	MBMS-GW.....	46
4a.14.4	Multi-cell/multicast Coordination Entity (MCE).....	46
4a.15	Void .....	46
4a.16	GUP Server.....	46
4a.17	Policy and Charging Rules Function (PCRF) .....	46
4a.18	Policy and Charging Enforcement Function (PCEF) .....	47
4a.19	Support of Short Message Service over generic 3GPP Internet Protocol access (SMSIP) specific entities.....	47
4a.19.1	General.....	47
4a.19.2	IP-Short-Message-Gateway (IP-SM-GW) .....	47
4a.20	Subscription Profile Repository (SPR).....	47
4a.21	Service Data Flow Based Credit Control Function .....	47
4a.22	Offline Charging System (OFCS).....	47
4a.23	Online Charging System (OCS).....	47
4a.24	Bearer Binding and Event Reporting Function (BBERF).....	47
4a.25	Home (e)NodeB entities .....	48
4a.25.1	Home NodeB Subsystem (HNS) .....	48
4a.25.2	Home eNodeB Subsystem (HeNS).....	48
4a.25.3	CSG List Server.....	48
4a.25.4	CSG Subscriber Server (CSS).....	48
4a.26	Application Front Ends (AFE).....	49
4a.27	User Data Repository (UDR).....	49
4a.28	Traffic Detection Function (TDF).....	49
4a.29	Specific entities to facilitate communications with packet data networks and applications .....	49
4a.29.1	Machine Type Communication-InterWorking Function (MTC-IWF) .....	49
4a.29.2	Machine Type Communication- Authentication, Authorization and Accounting (MTC-AAA) .....	49
4a.29.3	Service Capability Exposure Function (SCEF) .....	50
4a.30	TCP Proxy Function.....	50
4a.31	Specific entities for Packet Switched Streaming (PSS) Service.....	50
4a.31.1	Packet Switched Streaming Service Server (PSS Server) .....	50
4a.32	Specific entities for Group Communication System Enablers for LTE (GCSE_LTE).....	50
4a.32.1	Group Communication Service Application Server (GCS AS).....	50
4a.33	Specific entities for Proximity-based Services (ProSe).....	50
4a.33.1	ProSe Function .....	50
4a.34	RAN Congestion Awareness Function (RCAF) .....	51
4a.35	Traffic Steering Support Function (TSSF) .....	51
4a.36	Specific entities for mission critical communication services .....	51
4a.36.1	Mission Critical Push To Talk Application Server (MCPTT AS) .....	51
4a.37	Packet Flow Description Function (PFDF).....	51
4a.38	5G System architecture .....	51
5	Configuration of a Public Land Mobile Network .....	51
5.1	Basic configuration .....	51
5.2	Configuration of LCS entities.....	56
5.2.1	Configuration of LCS entities for GERAN .....	56
5.2.2	Configuration of LCS entities for UTRAN .....	57
5.2.3	Configuration of LCS entities for E-UTRAN.....	57
5.3	Configuration of CAMEL entities.....	58
5.4	Configuration of CBS entities.....	59
5.5	Configuration of IM CN Subsystem entities.....	59

5.5.1	IM CN Subsystem functional entities .....	59
5.5.2	IM CN Subsystem Service layer .....	60
5.5.3	Service Centralization and Continuity .....	62
5.5.4	WebRTC access to IMS .....	63
5.6	Configuration of Signalling Gateway Function .....	64
5.7	Configuration of 3GPP/WLAN Interworking .....	64
5.8	Configuration of Presence service .....	65
5.9	Configuration of MBMS entities .....	65
5.10	Configuration of Short Message Service over generic 3GPP Internet Protocol access (SMSIP) entities .....	67
5.11	Configuration of Policy Control and Charging entities .....	67
5.12	Configuration of CSFB(CS Fallback) .....	70
5.13	Configuration of Single Radio Voice Call Continuity (SRVCC) .....	71
5.13.1	E-UTRAN/UTRAN (HSPA) to UTRAN or GERAN SRVCC architecture .....	71
5.13.2	UTRAN/GERAN to E-UTRAN or UTRAN (HSPA) SRVCC architecture .....	72
5.14	Configuration of Security .....	74
5.15	Configuration of Lawful Intercept related entities .....	74
5.16	Configuration of Charging related entities .....	75
5.17	Configuration of Home (e)NodeB entities .....	76
5.17.1	Configuration of the Home NodeB Subsystem .....	76
5.17.2	Configuration of the Home eNodeB Subsystem .....	77
5.18	Configuration for facilitating communications with packet data networks and applications .....	78
5.19	Configuration of Packet Switched Streaming (PSS) Service .....	78
5.20	Configuration of Proximity-based Services .....	79
5.21	Configuration for RAN user plane congestion detection and reporting .....	79
6	PLMN basic interfaces and reference points .....	80
6.1	Interfaces between Mobile Station and the Fixed Infrastructure .....	80
6.1.1	Interface between Mobile Station and Base Station System (Um-interface) .....	80
6.1.2	Interface between User Equipment and Radio Network System (Uu-interface) .....	80
6.1.3	Interface between User Equipment and Evolved UTRAN (E-UTRAN Uu-interface) .....	80
6.2	Interface between the Core Network and the Access Network .....	80
6.2.1	Interfaces between the CS domain and the Access Network .....	80
6.2.1.1	Interface between the MSC and Base Station System (A-interface) .....	80
6.2.1.2	Interface between the MSC and Base Station System (Iu_CS interface) .....	81
6.2.1.3	Interface between the MSC and RNS (Iu_CS interface) .....	81
6.2.2	Interfaces between the PS domain and the Access Network .....	81
6.2.2.1	Interface between SGSN and BSS (Gb-interface) .....	81
6.2.2.2	Interface between SGSN and BSS (Iu_PS-interface) .....	81
6.2.2.3	Interface between SGSN and RNS (Iu_PS-interface) .....	81
6.2.3	Interfaces between the Evolved Packet Core and the Access Network .....	82
6.2.3.1	Interface between MME and E-UTRAN (S1-MME-interface) .....	82
6.2.3.2	Interface between S-GW and E-UTRAN (S1-U-interface) .....	82
6.3	Interfaces internal to the Access Network .....	82
6.3.1	Interface between BSC and BTS (Abis-interface) .....	82
6.3.2	Interface between RNC and Node B (Iub-interface) .....	82
6.3.3	Interface between two RNCs (Iur-interface) .....	82
6.3.4	Interface between two eNBs (X2-interface) .....	82
6.3.5	Interface between HNB and HNB-GW (Iuh-interface) .....	82
6.4	Interfaces internal to the Core Network .....	82
6.4.1	Interfaces internal to the CS domain .....	82
6.4.1.1	Interface between the MSC server and its associated VLR (B-interface) .....	82
6.4.1.2	Interface between the HLR and the MSC server (C-interface) .....	83
6.4.1.3	Interface between the HLR and the VLR (D-interface) .....	83
6.4.1.4	Interface between MSC servers or MSC server and IP-SM-GW (E-interface) .....	83
6.4.1.5	Interface between MSC server and EIR (F-interface) .....	83
6.4.1.6	Interface between VLRs (G-interface) .....	84
6.4.1.7	Reference point (G)MSC server – CS-MGW (Mc Reference Point) .....	84
6.4.1.8	Reference Point MSC Server – GMSC Server (Nc Reference Point) .....	84
6.4.1.9	Reference Point CS-MGW – CS-MGW (Nb Reference Point) .....	84
6.4.1.10	Reference Point between the CSS and the VLR (Hv Reference Point) .....	84
6.4.2	Interfaces internal to the PS domain (GPRS) .....	84
6.4.2.1	Interface between SGSN and HLR (Gr-interface) .....	84

6.4.2.2	Interface between SGSN and GGSN (Gn- and Gp-interface) .....	85
6.4.2.3	Signalling Path between GGSN and HLR (Gc-interface) .....	85
6.4.2.4	Interface between SGSN and EIR (Gf-interface) .....	85
6.4.2.5	Reference Point between the CSS and the Gn/Gp SGSN (Ghv Reference Point) .....	85
6.4.3	Interfaces used by CS and PS domains .....	85
6.4.3.1	Interface between MSC/VLR and SGSN (Gs-interface) for GPRS .....	85
6.4.3.2	Interface between HLR/HSS and AuC (H-Interface) .....	85
6.4.3.3	Interface between SGSN/IP-SM-GW and SMS-GMSC/SMS-IWMSC (Gd/Gdd-Interface) for GPRS .....	86
6.4.3.4	Interface between MSC/VLR and MME (SGs-interface) for EPC .....	86
6.4.3.5	Interface between 3GPP MSC Server and MME or SGSN (Sv-interface) .....	86
6.4.4	Interfaces internal & related to the Evolved Packet Core .....	86
6.4.4.1	Interface between MME and HSS (S6a-interface) .....	86
6.4.4.2	Interface between SGSN and HSS (S6d-interface) .....	86
6.4.4.3	Interface between MME and S-GW (S11-interface) .....	86
6.4.4.4	Interface between MME and MME (S10-interface) .....	87
6.4.4.5	Interface between S-GW and PDN GW (S5 and S8-interface) .....	87
6.4.4.6	Interface between MME and EIR (S13-interface) .....	87
6.4.4.7	Interface between MME and SGSN (S3-interface) .....	87
6.4.4.8	Interface between S-GW and SGSN (S4-interface) .....	87
6.4.4.9	Interface between S-GW and UTRAN (S12-interface) .....	87
6.4.4.10	Interface between Trusted non-3GPP IP Access and S-GW/PDN GW (S2a-interface) .....	87
6.4.4.11	Interface between PDN GW/S-GW and ePDG (S2b-interface) .....	87
6.4.4.12	Interface between PDN GW and UE (S2c-interface) .....	87
6.4.4.13	Interface between PDN GW and 3GPP AAA Server/proxy (S6b-interface) .....	87
6.4.4.14	Interface between Untrusted non-3GPP IP Access and 3GPP AAA Server/proxy (SWa-interface) .....	88
6.4.4.15	Interface between Trusted non-3GPP IP Access and 3GPP AAA Server/proxy (STa-interface) .....	88
6.4.4.16	Interface between 3GPP AAA Server and 3GPP AAA proxy (SWd-interface) .....	88
6.4.4.17	Interface between ePDG and 3GPP AAA Server/proxy (SWm-interface) .....	88
6.4.4.18	Interface between ePDG and Untrusted non-3GPP Access (SWn-interface) .....	88
6.4.4.19	Interface between ePDG and UE (SWu-interface) .....	88
6.4.4.20	Interface between HSS and 3GPP AAA Server (SWx-interface) .....	88
6.4.4.21	Interface between UE and ANDSF (S14-interface) .....	88
6.4.4.22	Reference point between HRDP AN and MME (S101-reference point) .....	88
6.4.4.23	Reference point between 3GPP2 1xCS IWS and MME (S102-reference point) .....	89
6.4.4.24	Interface between HSGW and S-GW (S103-interface) .....	89
6.4.4.25	Reference point between UE and CSG List Server (Uh reference point) .....	89
6.4.4.26	Reference Point between the CSS and the S4-SGSN (S7d Reference Point) .....	89
6.4.4.27	Reference point between the CSS and the MME (S7a reference point) .....	89
6.4.4.28	Reference point between the MME and the SMS-GMSC/SMS-IWMSC/SMS Router (SGd reference point) .....	89
6.4.4.29	Reference point between the HSS and the SMS-GMSC/SMS-IWMSC/SMS Router (S6c reference point) .....	89
6.4.4.30	Reference point between HRPD AN and MME (S121-interface) .....	89
6a	PLMN specific interfaces .....	90
6a.1	GCR-specific interface .....	90
6a.1.1	Interface between the MSC and its associated GCR (I-interface) .....	90
6a.2	(void) .....	90
6a.3	LCS-specific interfaces .....	90
6a.3.1	LCS interfaces using MAP .....	90
6a.3.2	(void) .....	90
6a.3.3	(void) .....	90
6a.3.4	(void) .....	90
6a.3.5	Interface between BSC and SMLC (Lb-interface) .....	90
6a.3.6	Interface between Peer SMLCs (Lp-interface) .....	90
6a.3.7	Interface between BTS and LMU (Um-interface) .....	91
6a.3.8	Interface between GMLC and External LCS Client (Le-interface) .....	91
6a.3.9	Interface between RNS and Stand-Alone LMU, UE (Uu-interface) .....	91
6a.3.10	Interface between SRNC and SAS (Stand-Alone SMLC) (Iupc-interface) .....	91
6a.3.11	Interface between GMLC and GMLC (Lr-interface) .....	91
6a.3.12	Interface between GMLC and MME (SLg-interface) .....	91

6a.3.13	Interface between MME and E-SMLC (SLs-interface) .....	91
6a.3.14	Interface between GMLC and HSS (SLh-interface) .....	91
6a.3.15	Interface between GMLC and SGSN (Lgd-interface).....	91
6a.4	CAMEL-specific interfaces .....	92
6a.4.1	GMSC - gsmSSF interface.....	92
6a.4.2	gsmSSF - gsmSCF interface .....	92
6a.4.3	MSC - gsmSSF interface .....	92
6a.4.4	gsmSCF - HLR interface .....	92
6a.4.5	gsmSCF - gsmSRF interface.....	92
6a.4.6	MSC - gsmSCF interface.....	92
6a.4.7	SGSN - gprsSSF interface .....	92
6a.4.8	gprsSSF - gsmSCF interface (Ge Reference Point).....	92
6a.5	CBS-specific interfaces .....	92
6a.5.1	Interface between the CBC and RNS (Iu_BC Interface).....	92
6a.5.2	Interface between the CBC and MME (SBc Interface).....	93
6a.5.3	Interface between the CBC and BSC .....	93
6a.6	Number portability specific interfaces .....	93
6a.6.1	IN-based solution.....	93
6a.6.1.1	NPDB to MSC interface .....	93
6a.6.2	Signalling Relay-based solution .....	93
6a.6.2.1	GMSC to MNP-SRF interface .....	93
6a.6.2.2	MNP-SRF to HLR interface .....	93
6a.7	IM Subsystem Reference Points .....	93
6a.7.1	Reference Point HSS – CSCF (Cx Reference Point) .....	93
6a.7.2	Reference Point CSCF – UE (Gm Reference Point).....	94
6a.7.3	Reference Point MGCF – IMS-MGW (Mn Reference Point) .....	94
6a.7.4	Reference Point MGCF – CSCF (Mg Reference Point).....	94
6a.7.5	(void) .....	94
6a.7.5a	Reference Point AS-MRFC for media control (Cr Reference Point).....	94
6a.7.5b	Reference Point AS-MRFC for session control (Mr' Reference Point).....	94
6a.7.6	Reference Point CSCF - MRFC (Mr Reference Point).....	95
6a.7.6a	Reference Point MRFC – MRFP (Mp Reference Point).....	95
6a.7.7	Reference Point CSCF – CSCF (Mw Reference Point) .....	95
6a.7.8	(void) .....	95
6a.7.8a	Reference Point CSCF – MRB (ISC Reference Point) .....	95
6a.7.9	(void) .....	95
6a.7.9a	Reference Point AS – MRB (Rc Reference Point) .....	95
6a.7.10	Reference Point CSCF – BGCF (Mi reference point).....	95
6a.7.11	Reference Point BGCF – MGCF (Mj reference point) .....	95
6a.7.12	Reference Point BGCF/IBCF – BGCF (Mk reference point).....	96
6a.7.13	Reference Point CSCF- SLF (Dx Reference Point).....	96
6a.7.14	Reference Point to IMS media plane (Mb reference point).....	96
6a.7.15	Reference Point S-CSCF – AS (ISC Reference Point).....	96
6a.7.15a	Reference Point E-CSCF - EATF (I4 Reference Point).....	96
6a.7.15b	Reference Point I-CSCF - EATF (I5 Reference Point).....	96
6a.7.16	Reference Point HSS – SIP AS or OSA SCS (Sh Reference Point) .....	96
6a.7.17	Reference Point HSS – CAMEL IM-SSF (Si Reference Point) .....	96
6a.7.18	Reference Point UE – AS (Ut Reference Point) .....	96
6a.7.19	Reference Point AS- SLF (Dh Reference Point) .....	97
6a.7.20	Reference Point CSCF/BGCF - IBCF (Mx Reference Point).....	97
6a.7.21	Reference Point IBCF - TrGW (Ix Reference Point).....	97
6a.7.22	Reference Point I-CSCF – AS (Ma Reference Point) .....	97
6a.7.23	Reference Point P-CSCF – IMS Access Gateway (Iq Reference Point) .....	97
6a.7.23a	Reference Point E-CSCF - LRF (MI Reference Point) .....	97
6a.7.24	Reference Point IBCF - IBCF (Ici Reference Point).....	97
6a.7.25	Reference Point TrGW - TrGW (Izi Reference Point).....	97
6a.7.26	Void .....	98
6a.7.27	Reference Point MSC Server - CSCF (I2 Reference Point) .....	98
6a.7.28	Reference Point MSC Server - TAS (I3 Reference Point) .....	98
6a.7.29	Reference Point ICS UE – SCC AS (I1 Reference Point).....	98
6a.7.30	Reference Point IBCF - Application Server (AS) (Ms Reference Point).....	98
6a.8	Void .....	98

6a.9	Reference Points for 3GPP/WLAN Interworking.....	98
6a.9.1	Reference point 3GPP AAA Server - HLR (D'/Gr' Reference Point).....	98
6a.9.2	Reference point WLAN access network - 3GPP AAA Proxy/Server (Wa Reference Point).....	99
6a.9.3	Reference point 3GPP AAA Server – 3GPP AAA Proxy (Wd Reference Point).....	99
6a.9.4	Reference point 3GPP AAA Server/Proxy - WAG (Wg Reference Point).....	99
6a.9.5	Reference point PDG - packet data networks (Wi Reference Point).....	99
6a.9.6	Reference Point 3GPP AAA Server/Proxy - PDG (Wm Reference Point).....	99
6a.9.7	Reference Point WAG - WLAN access network (Wn Reference Point).....	99
6a.9.8	Reference Point WAG - PDG (Wp Reference Point).....	99
6a.9.9	Reference point WLAN UE - PDG (Wu Reference Point).....	99
6a.9.10	Reference point WLAN UE - WLAN access network (Ww Reference Point).....	100
6a.9.11	Reference point 3GPP AAA Server - HSS (Wx Reference Point).....	100
6a.9.12	Reference point 3GPP AAA Server - SLF (Dw reference point).....	100
6a.10	MBMS specific reference points for GPRS.....	100
6a.10.1	Reference point GGSN – BM-SC (Gmb Reference Point).....	100
6a.10.2	Reference point BM-SC – BM-SC (Mz Reference Point).....	100
6a.10.3	Reference point GGSN – RNS (or BSS Iu mode) (Gmc Reference Point).....	100
6a.11	MBMS specific reference points for EPS.....	101
6a.11.1	Reference point MBMS-GW – BM-SC (SGmb Reference Point).....	101
6a.11.2	Reference point MBMS-GW – BM-SC (SGi-mb Reference Point).....	101
6a.11.3	Reference point MBMS-GW - MME (Sm Reference Point).....	101
6a.11.4	Reference point MBMS-GW – SGSN (Sn Reference Point).....	101
6a.11.5	Reference point MBMS-GW – E-UTRAN/UTRAN (M1 Reference Point).....	101
6a.11.6	Reference point MME – MCE (M3 Reference Point).....	101
6a.11.7	Reference point MCE - eNodeB (M2 Reference Point).....	101
6a.11.8	Reference point Content Provider/SCEF - BM-SC (xMB Reference Point).....	101
6a.12	Reference Points for 3GPP Generic User Profile (GUP).....	101
6a.12.1	Reference Point GUP Server – Applications (Rg Reference Point).....	101
6a.12.2	Reference Point GUP Server – HSS and Applications – HSS (Rp Reference Point).....	102
6a.13	Reference Points for Policy and Charging Control.....	102
6a.13.1	Reference Point PCEF - PCRF/H-PCRF/V-PCRF (Gx Reference Point).....	102
6a.13.2	Reference Point PCRF - Application Function (Rx Reference Point).....	102
6a.13.3	Reference Point SPR – PCRF (Sp Reference Point).....	102
6a.13.4	Reference Point OCS – PCEF (Gy Reference Point).....	102
6a.13.5	Reference Point OFCS – PCEF (Gz Reference Point).....	102
6a.13.6	Reference Point Trusted non-3GPP IP Access and PCRF/VPCRF (Gxa Reference Point).....	102
6a.13.7	Reference Point ePDG and PCRF/VPCRF (Gxb Reference Point).....	102
6a.13.7a	Reference Point ePDG and PCRF/VPCRF (Gxb* Reference Point).....	103
6a.13.8	Reference point between S-GW and PCRF/VPCRF (Gxc-interface).....	103
6a.13.9	Reference Point PCRF/VPCRF – BBERF (Gxx Reference Point).....	103
6a.13.10	Reference Point HPCRF - VPCRF (S9- interface).....	103
6a.13.11	Reference Point UDR – PCRF (Ud Reference Point).....	103
6a.13.12	Reference Point TDF - PCRF/H-PCRF/V-PCRF (Sd Reference Point).....	103
6a.13.13	Reference Point OCS - PCRF/H-PCRF (Sy Reference Point).....	103
6a.13.14	Reference Point HNB GW - PCRF/V-PCRF (S15 Reference Point).....	103
6a.13.15	Reference Point BPCF - PCRF/v-PCRF (S9a Reference Point).....	103
6a.13.16	Reference Point OCS - TDF (Gyn Reference Point).....	104
6a.13.17	Reference Point OFCS - TDF (Gzn Reference Point).....	104
6a.13.18	Void.....	104
6a.13.19	Reference Point TSSF - PCRF/H-PCRF (St Reference Point).....	104
6a.13.20	Reference point between PFDF and PCEF (Gw reference point).....	104
6a.13.21	Reference point between PFDF and TDF (Gwn reference point).....	104
6a.14	SMSIP specific reference points.....	104
6a.14.1	Reference point IP-SM-GW – HSS (J Reference Point).....	104
6a.15	User Data Convergence specific reference points.....	104
6a.15.1	Reference point Application Front Ends - UDR (Ud Reference Point).....	104
6a.16	Specific reference points for facilitating communications with packet data networks and applications.....	104
6a.16.1	Reference point MTC-IWF - SCS (Tsp reference point).....	104
6a.16.2	Reference point MTC-IWF - HSS/HLR (S6m reference point).....	105
6a.16.3	Reference point MTC-AAA - HSS/HLR (S6n reference point).....	105
6a.16.4	Reference point MTC-IWF - SMS-SC (T4 reference point).....	105
6a.16.5	Reference point between the HSS and the SCEF (S6t reference point).....	105

6a.16.6	Reference point between the MME and the SCEF (T6a reference point) .....	105
6a.16.7	Reference point between the SGSN and the SCEF (T6b reference point) .....	105
6a.16.8	Reference point between the RCAF and the SCEF (Ns reference point) .....	105
6a.16.9	Reference point between the PCRF and the SCEF (Nt reference point) .....	106
6a.16.10	Reference point between the PFDF and the SCEF (Nu reference point).....	106
6a.17	GCSE_LTE specific reference points.....	106
6a.17.1	Reference point GCS AS - BM-SC (MB2 Reference Point).....	106
6a.17.2	Reference point GCS AS - UE (GC1 Reference Point) .....	106
6a.18	ProSe specific reference points.....	106
6a.18.1	Reference point UE - ProSe Application Server (PC1 Reference Point) .....	106
6a.18.2	Reference point ProSe Function - ProSe Application Server (PC2 Reference Point) .....	106
6a.18.3	Reference point UE - ProSe Function (PC3 Reference Point).....	106
6a.18.4	Reference point HSS - ProSe Function (PC4a Reference Point) .....	107
6a.18.5	Reference point SLP - ProSe Function (PC4b Reference Point) .....	107
6a.18.6	Reference point UE - UE (PC5 Reference Point).....	107
6a.18.7	Reference point ProSe Function - ProSe Function in different PLMNs (PC6 Reference Point) .....	107
6a.18.8	Reference point ProSe Function in HPLMN - ProSe Function in VPLMN (PC7 Reference Point) .....	107
6a.19	Reference points for RAN user plane congestion detection and reporting .....	107
6a.19.1	Reference Point RCAF - PCRF/ V-PCRF (Np Reference Point).....	107
6a.19.2	Reference point between MME and RCAF (Nq reference point).....	107
6a.19.3	Reference point between SGSN and RCAF (Nq' reference point).....	107
7	Reference points between the PLMN and other networks .....	108
7.1	Reference point fixed networks - MSC .....	108
7.2	Reference point GGSN - packet data networks (Gi reference point) .....	108
7.2a	Reference point PDN GW - packet data networks (SGi reference point).....	108
7.3	Reference point GMLC - external LCS Client (Le reference point) .....	108
7.4	Reference Point CSCF/IBCF – Multimedia IP networks (Mm Reference Point) .....	108
7.5	(void).....	108
7.6	Reference point PDG - packet data networks (Wi reference point) .....	108
7.7	Reference Point WAG – WLAN access network (Wn reference point).....	109
7.8	Reference point MTC-IWF - SCS (Tsp reference point).....	109
<b>Annex A (informative):</b>	<b>Description for GLR-related entities and interfaces .....</b>	<b>110</b>
A.1	Normative references .....	110
A.2	Definitions related to Gateway Location Register (GLR).....	110
A.2.1	Gateway Location Register (GLR).....	110
A.2.2	Intermediate Mobile-services Switching Centre (IM-MSC).....	110
A.2.3	Intermediate GPRS Serving Node (IM-GSN).....	110
A.3	The entities of the mobile system .....	110
A.3.1	Gateway Location Register (GLR).....	110
A.3.2	Intermediate Mobile-services Switching Centre (IM-MSC).....	111
A.3.3	Intermediate GPRS Serving Node (IM-GSN).....	111
A.4	Configuration of a Public Land Mobile Network .....	111
A.4.1	Basic configuration with GLR introduction.....	111
A.5	PLMN interfaces.....	112
A.5.1	Interface between the HLR and the GLR (GLa-interface).....	112
A.5.2	Interface between the VLR and the GLR (GLb-interface) .....	112
A.5.3	Interface between the SGSN and the GLR (GLc-interface).....	112
A.5.4	Interface between the GLR and the IM_MSC (GLd-interface) .....	112
A.5.5	Interface between the GLR and the IM_GSN (GLe-interface) .....	112
A.5.6	Interface between the SMS-GMSC and the GLR (GLf-interface) .....	113
A.5.7	Interface between the SMS-GMSC and the IM_MSC (GLg-interface).....	113
A.5.8	Interface between the MSC and the IM_MSC (GLh-interface) .....	113
A.5.9	Interface between the GMLC and the IM_MSC (GLi-interface) .....	113
A.5.10	Interface between the GGSN and the IM_GSN (GLj-interface).....	113
A.5.11	Interface between the SGSN and the IM_GSN (GLk-interface).....	113

**Annex B (informative):**    **Change history** ..... 114

---

## Foreword

This Technical Specification (TS) has been produced by the 3rd Generation Partnership Project (3GPP).

The contents of the present document are subject to continuing work within the TSG and may change following formal TSG approval. Should the TSG modify the contents of the present document, it will be re-released by the TSG with an identifying change of release date and an increase in version number as follows:

Version x.y.z

where:

- x the first digit:
  - 1 presented to TSG for information;
  - 2 presented to TSG for approval;
  - 3 or greater indicates TSG approved document under change control.
- y the second digit is incremented for all changes of substance, i.e. technical enhancements, corrections, updates, etc.
- z the third digit is incremented when editorial only changes have been incorporated in the document.

---

## Introduction

This document presents the possible architectures of the 3GPP System covering both UTRAN and GERAN radio access technologies. In addition, this document also includes the Evolved Packet System providing support for E-UTRAN radio access technology in addition to UTRAN and GERAN radio access technologies. As well as providing support for E-UTRAN, UTRAN and GERAN radio access technologies, the Evolved Packet System also provides support for non-3GPP access technologies making it possible for these technologies to interwork with the 3GPP specified Evolved Packet Core network. The configuration of non-3GPP access networks using EPS is not within the scope of 3GPP specification.

This document also presents the architecture for the IP Multimedia Subsystem common to 3GPP and other access systems such as Fixed Broadband and those specified by 3GPP2 and provide architecture for interworking and session continuity between IMS and Circuit Switched systems.

Clause 3 of the document contains the definition of the PLMN entities.

Clause 4 of the document contains the description of the basic entities of the PLMN, and clause 4a contains the description of the specific entities of the PLMN.

Clause 5 of the document contains the configuration of the PLMN.

Clauses 6, 6a and 7 of the document contain the PLMN's basic and specific interfaces and reference points and the PLMN's interfaces towards other networks.

---

# 1 Scope

This document offers an overview of the 3GPP PLMN and its architectures and configuration. The configuration and the functional entities of the PLMN and the interfaces between them are described on a general level in order to cope with possible implementations. These descriptions include interfaces between and within the core networks, the access networks, the user equipment, different service platforms, different domains and subsystems, and functional entities within domains and subsystems.

This document covers different architectural aspects with varying level of detail. In general, other specifications shall be referred to for further details; these specifications enable the reader to acquire the full understanding of a system or service feature.

Note that this document does not cover, or even list, all features of PLMNs.

---

# 2 References

The following documents contain provisions which, through reference in this text, constitute provisions of the present document.

- References are either specific (identified by date of publication, edition number, version number, etc.) or non-specific.
- For a specific reference, subsequent revisions do not apply.
- For a non-specific reference, the latest version applies. In the case of a reference to a 3GPP document (including a GSM document), a non-specific reference implicitly refers to the latest version of that document *in the same Release as the present document*.

- [1] Void.
- [1a] 3GPP TR 21.905: "Vocabulary for 3GPP Specifications".
- [2] 3GPP TS 22.016: "International Mobile station Equipment Identities (IMEI)".
- [2a] 3GPP TS 22.060: "General Packet radio Service (GPRS); Service description; Stage 1".
- [2b] 3GPP TS 22.071: "Location Services (LCS); Service description; Stage 1".
- [2c] 3GPP TS 22.078: "Customised Applications for Mobile network Enhanced Logic (CAMEL); Service description, Stage 1".
- [3] 3GPP TS 23.003: "Numbering, addressing and identification".
- [4] 3GPP TS 22.127: "Open Service Access (OSA)".
- [5] 3GPP TS 23.008: "Organization of subscriber data".
- [6] 3GPP TS 23.009: "Handover procedures".
- [7] 3GPP TS 23.012: "Location Management Procedures".
- [8] 3GPP TS 23.041: "Technical realization of Cell Broadcast Service (CBS)".
- [9] Void.
- [9a] 3GPP TS 23.060: "General Packet Radio Service (GPRS); Service description; Stage 2".
- [10] Void.
- [10a] 3GPP TS 43.064: "Digital cellular telecommunication system (Phase 2+); General Packet Radio service (GPRS); Overall description of the GPRS radio interface; Stage 2".
- [10b] 3GPP TS 25.305: "Stage 2 Functional Specification of UE Positioning in UTRAN".

- [10c] 3GPP TS 23.078: "Customised Applications for Mobile network Enhanced Logic (CAMEL) Phase 3 - Stage 2".
- [10d] 3GPP TS 43.059: "Functional Stage 2 Description of Location Services in GERAN".
- [11] ITU-T Recommendation Q.1214 (05/1995): "Distributed Functional Plane for Intelligent Network CS-1".
- [11a] 3GPP TS 23.101: "General UMTS Architecture".
- [11b] 3GPP TS 23.110: "UMTS Access Stratum); Services and Functions".
- [12] 3GPP TS 24.002: "GSM - UMTS Public Land Mobile Network (PLMN) access reference configuration".
- [13] 3GPP TS 48.001: "Base Station System - Mobile-services Switching Centre (BSS - MSC) interface; General aspects".
- [14] 3GPP TS 48.002: "Base Station System - Mobile-services Switching Centre (BSS - MSC) interface; Interface principles".
- [14a] 3GPP TS 25.410: "UTRAN Iu Interface: general aspects and principles".
- [15] 3GPP TS 48.004: "Base Station System - Mobile-services Switching Centre (BSS - MSC) interface Layer 1 specification".
- [16] 3GPP TS 48.006: "Signalling transport mechanism specification for the Base Station System - Mobile-services Switching Centre (BSS - MSC) interface".
- [17] 3GPP TS 48.008: "Mobile-services Switching Centre - Base Station System (MSC - BSS) interface; Layer 3 specification".
- [18] Void.
- [19] 3GPP TS 48.051: "Base Station Controller - Base Transceiver Station (BSC - BTS) interface; General aspects".
- [20] 3GPP TS 48.052: "Base Station Controller - Base Transceiver Station (BSC - BTS) interface; Interface principles".
- [21] 3GPP TS 48.054: "Base Station Controller - Base Transceiver Station (BSC - BTS) interface; Layer 1 structure of physical circuits".
- [22] 3GPP TS 48.056: "Base Station Controller - Base Transceiver Station (BSC - BTS) interface; Layer 2 specification".
- [23] 3GPP TS 48.058: "Base Station Controller - Base Transceiver Station (BSC - BTS) interface; Layer 3 specification".
- [24] 3GPP TS 48.060: "In-band control of remote transcoders and rate adaptors for full rate traffic channels".
- [25] 3GPP TS 48.061: "In-band control of remote transcoders and rate adaptors for half rate traffic channels".
- [26] 3GPP TS 29.002: "Mobile Application Part (MAP) specification".
- [27] 3GPP TS 22.228: "Service requirements for the IP Multimedia Core Network Subsystem".
- [28] 3GPP TS 23.207: "End-to-end Quality of Service (QoS) concept and architecture".
- [29] [void].
- [30] [void].

- [31] 3GPP TS 29.007: "General requirements on interworking between the Public Land Mobile Network (PLMN) and the Integrated Services Digital Network (ISDN) or Public Switched Telephone Network (PSTN)".
- [32] 3GPP TS 29.010: "Information element mapping between Mobile Station - Base Station System (MS – BSS) and Base Station System - Mobile-services Switching Centre (BSS - MSC); Signalling procedures and the Mobile Application Part (MAP)".
- [33] 3GPP TS 29.011: "Signalling interworking for supplementary services".
- [34] 3GPP TS 23.228: "IP Multimedia Subsystem (IMS); Stage 2".
- [35] 3GPP TS 41.103: "GSM Release 5 specifications".
- [36] 3GPP TS 43.051: "Technical Specification Group GSM/EDGE Radio Access Network; Overall description, Stage 2".
- [37] 3GPP TS 23.226: "Global Text Telephony (GTT); Stage 2".
- [38] 3GPP TS 26.226: "Cellular Text Telephone Modem; General Description".
- [39] 3GPP TS 23.016: "Subscriber data management; Stage 2".
- [40] 3GPP TS 23.066: "Support of Mobile Number Portability (MNP); Technical realization; Stage 2".
- [41] 3GPP TS 43.068: "Voice Group Call Service (VGCS); Stage 2".
- [42] 3GPP TS 43.069: "Voice Broadcast Service (VBS); Stage 2".
- [43] 3GPP TS 23.205: "Bearer independent circuit switched core network; Stage 2".
- [44] 3GPP TS 48.014: "Base Station System (BSS) – Serving GPRS Support Node (SGSN) interface; Gb interface Layer 1".
- [45] 3GPP TS 48.016: "Base Station System (BSS) – Serving GPRS Support Node (SGSN) interface; Network service".
- [46] 3GPP TS 48.018: "Base Station System (BSS) – Serving GPRS Support Node (SGSN); BSS GPRS Protocol (BSSGP)".
- [47] 3GPP TS 48.031: "Serving Mobile Location Centre – Serving Mobile Location Centre (SMLC – SMLC); SMLCPP specification".
- [48] 3GPP TS 29.016: "Serving GPRS Support Node (SGSN) – Visitor Location Register (VLR); Gs interface network service specification".
- [49] 3GPP TS 29.018: "Serving GPRS Support Node (SGSN) – Visitor Location Register (VLR); Gs interface Layer 3 specification".
- [50] 3GPP TS 49.031: "Network Location Services (LCS); Base Station System Application Part LCS extension (BSSAP-LE)".
- [51] 3GPP TS 29.060: "GPRS Tunnelling Protocol (GTP) across the Gn and Gp Interface".
- [52] ITU-T Recommendation H.248: "Gateway Control Protocol".
- [53] ITU-T Recommendation E.164: "The International public telecommunication numbering plan".
- [54] ITU-T Recommendation H.323: "Packet-based multimedia communications systems".
- [55] 3GPP TS 44.071: "Mobile radio interface layer 3 Location Services (LCS) specification".
- [56] 3GPP TS 23.271: "Functional stage 2 description of LCS".
- [57] ITU-T Recommendation I.363-2 : "B-ISDN ATM Adaptation Layer (AAL) type 2 specification".
- [58] ITU-T Recommendation H.245: "Control protocol for multimedia communication".

- [59] IETF RFC 768: "User Datagram Protocol".
- [60] IETF RFC 1889: "RTP: A Transport Protocol for Real-Time Applications".
- [61] IETF RFC 3261: "SIP: Session Initiation Protocol".
- [62] OMA MLP TS: "Mobile Location Protocol", [<http://www.openmobilealliance.org/>].
- [63] 3GPP TS 29.198: "Open Service Access (OSA) Application Programming Interface (API)".
- [64] 3GPP TS 33.210: "3G Security; Network Domain Security; IP network layer security".
- [65] 3GPP TS 23.236: "Intra Domain Connection of RAN Nodes to Multiple CN Nodes".
- [66] 3GPP TS 25.453: "UTRAN Iupc interface Positioning Calculation Application Part (PCAP) signalling".
- [67] 3GPP TS 23.234: "3GPP system to Wireless Local Area Network (WLAN) interworking".
- [68] 3GPP TS 23.141: "Presence Service; Architecture and functional description".
- [69] OMA RLP TS: "Roaming Location Protocol", [<http://www.openmobilealliance.org/>].
- [70] 3GPP TS 23.246: "Multimedia Broadcast/Multicast Service (MBMS); Architecture and functional description".
- [71] 3GPP TS 23.240: "3GPP Generic User Profile (GUP); Architecture (Stage 2)".
- [72] 3GPP TS 33.222: "Generic Authentication Architecture (GAA); Access to network application functions using Hypertext Transfer Protocol over Transport Layer Security (HTTPS)".
- [73] 3GPP TS 23.203: "Policy Control and Charging Architecture (Stage 2)".
- [74] 3GPP TS 23.167: "IP Multimedia Subsystem (IMS) emergency sessions".
- [75] 3GPP TS 23.204: "Support of Short Message Service (SMS) over generic 3GPP Internet Protocol (IP) access".
- [76] 3GPP TS 23.401: "General Packet Radio Service (GPRS) enhancements for Evolved Universal Terrestrial Radio Access Network (E-UTRAN) access".
- [77] 3GPP TS 23.402: "Architecture enhancements for non-3GPP accesses".
- [78] 3GPP TS 36.300: "Evolved Universal Terrestrial Radio Access (E-UTRA) and Evolved Universal Terrestrial Radio Access Network (E-UTRAN); Overall description; Stage 2".
- [79] 3GPP TS 36.401: "Evolved Universal Terrestrial Radio Access Network (E-UTRAN); Architecture description".
- [80] Open Mobile Alliance, OMA ERP SUPL V2.0: "Secure User Plane Location Enabler Release Package", (<http://www.openmobilealliance.org/>).
- [81] 3GPP TS 23.272: "Circuit Switched Fallback in Evolved Packet System; Stage 2".
- [82] 3GPP TS 29.118: "Mobility Management Entity (MME) – Visitors Location Register (VLR) SGs interface specification".
- [83] 3GPP TS 23.216: "Single Radio Voice Call Continuity (SRVCC); Stage 2".
- [84] 3GPP TS 33.107: "3G security; Lawful interception architecture and functions".
- [85] 3GPP TS 32.240: "Telecommunication management; Charging management; Charging architecture and principles".
- [86] 3GPP TS 29.272: "Evolved Packet System (EPS); Mobility Management Entity (MME) and Serving GPRS Support Node (SGSN) related interfaces based on Diameter protocol".
- [87] 3GPP TS 33.401: "3GPP System Architecture Evolution (SAE); Security architecture".

- [88] 3GPP TS 33.402: "3GPP System Architecture Evolution (SAE); Security aspects of non-3GPP accesses".
- [89] 3GPP TS 24.301: "Non-Access-Stratum (NAS) protocol for Evolved Packet System (EPS); Stage 3".
- [90] 3GPP TS 29.274: "General Packet Radio Service (GPRS); Evolved GPRS Tunnelling Protocol (eGTP) for EPS".
- [91] 3GPP TS 29.280: "Evolved Packet System (EPS); 3GPP Sv interface (MME to MSC, and SGSN to MSC) for SRVCC".
- [92] 3GPP TS 29.213: "PCC Signalling Flows and Mapping Tables".
- [93] 3GPP TS 29.275: "Proxy Mobile IPv6 (PMIPv6) based Mobility and Tunnelling protocols; Stage 3".
- [94] 3GPP TS 24.304: "Mobility management based on Mobile IPv4; User Equipment (UE) - foreign agent interface; Stage 3".
- [95] 3GPP TS 24.303: "Mobility management based on Dual-Stack Mobile IPv6; Stage 3".
- [96] 3GPP TS 29.273: "Evolved Packet System (EPS); 3GPP EPS AAA interfaces".
- [97] 3GPP TS 24.302: "Access to the 3GPP Evolved Packet Core (EPC) via non-3GPP access networks".
- [98] 3GPP TS 29.168: "Cell Broadcast Centre interfaces with the Evolved Packet Core; Stage 3".
- [99] 3GPP TS 29.212: "Policy and Charging Control (PCC); Reference points".
- [100] 3GPP TS 29.214: "Policy and Charging Control over Rx Interface".
- [101] 3GPP TS 32.251: "Telecommunication management; Charging management; Packet Switched (PS) domain charging".
- [102] IETF RFC 4006: "Diameter Credit-Control Application".
- [103] 3GPP TS 29.215: "Policy and Charging Control over S9 Interface".
- [104] 3GPP TS 29.061: "Interworking between PLMN supporting packet based services and PDN".
- [105] Void.
- [106] 3GPP2 A.S0008-C: "Interoperability Specification (IOS) for High Rate Packet Data (HRPD) Radio Access Network Interfaces with Session Control in the Access Network".
- [107] 3GPP2 C.S0087 0: "E-UTRAN - HRPD and CDMA2000 1x Connectivity and Interworking: Air Interface Aspects".
- [108] 3GPP TS 32.296: "Telecommunication management; Charging management; Online Charging System (OCS)erw 321.7 Tm 0.00336 Tc[([105])] Tjrw 321.7 Tm 0.00336 Tc[([n]-23(d)-11(P)8(D)8(N)8(")27(.

- [116] 3GPP TS 25.469: "UTRAN Iuh interface Home Node B (HNB) Application Part (HNBAP) signalling".
- [117] 3GPP TS 24.285: "Allowed Closed Subscriber Group (CSG) List; Management Object (MO)".
- [118] 3GPP TS 31.102: "Characteristics of the Universal Subscriber Identity Module (USIM) application".
- [119] 3GPP TS 48.049: "Base Station Controller - Cell Broadcast Centre (BSC-CBC) Interface Specification; Cell Broadcast Service Protocol (CBSP)".
- [120] 3GPP TS 23.335: "User Data Convergence (UDC); Technical realization and information flows; Stage 2".
- [121] 3GPP TS 29.335: "User Data Convergence (UDC); User Data Repository Access Protocol over the Ud interface; Stage 3".
- [122] 3GPP TS 36.305: "Evolved Universal Terrestrial Radio Access Network (E-UTRAN); Stage 2 functional specification of User Equipment (UE) positioning in E-UTRAN".
- [123] 3GPP TS 29.172: "Location Services (LCS); Evolved Packet Core (EPC) LCS Protocol (ELP) between the Gateway Mobile Location Centre (GMLC) and the Mobile Management Entity (MME); SLg interface".
- [124] 3GPP TS 29.171: "Location Services (LCS); LCS Application Protocol (LCS-AP) between the Mobile Management Entity (MME) and Evolved Serving Mobile Location Centre (E-SMLC); SLs interface".
- [125] 3GPP TS 29.173: "Location Services (LCS); Diameter-based SLh interface for Control Plane LCS".
- [126] 3GPP TS 29.281: "GPRS Tunnelling Protocol User Plane (GTPv1-U)".
- [127] 3GPP TS 36.443: "Evolved Universal Terrestrial Radio Access Network (E-UTRAN); M2 Application Protocol (M2AP)".
- [128] 3GPP TS 36.444: "Evolved Universal Terrestrial Radio Access Network (E-UTRAN); M3 Application Protocol (M3AP)".
- [129] 3GPP TS 36.445: "Evolved Universal Terrestrial Radio Access Network (E-UTRAN); M1 data transport".
- [130] 3GPP TS 22.220: "Service Requirements for Home NodeBs and Home eNodeBs".
- [131] 3GPP TS 29.219: "Policy and charging control: Spending limit reporting over Sy reference point".
- [132] 3GPP TS 23.682: "Architecture enhancements to facilitate communications with packet data networks and applications".
- [133] 3GPP TS 29.336: "Home Subscriber Server (HSS) diameter interfaces for interworking with packet data networks and applications".
- [134] 3GPP TS 29.337: "Diameter based T4 Interface for communications with packet data networks and applications".
- [135] 3GPP TS 29.338: "Diameter based protocols to support of SMS capable MMEs".
- [136] 3GPP TS 29.368: "Tsp interface protocol between the MTC Interworking Function (MTC-IWF) and Service Capability Server (SCS)".
- [137] 3GPP TS 23.040: "Technical realization of the Short Message Service (SMS)".
- [138] IETF RFC 793 (1981): "Transmission Control Protocol" (STD 7).
- [139] 3GPP TS 26.233: "Transparent end-to-end Packet-switched Streaming Service (PSS); General Description".

- [140] 3GPP TS 23.468: "Group Communication System Enablers for LTE (GCSE\_LTE); Stage 2".
- [141] 3GPP TS 23.303: "Proximity-based services (ProSe); Stage 2".
- [142] 3GPP TS 23.179: "Functional architecture and information flows to support mission critical communication services; Stage 2".
- [143] 3GPP TS 26.114: "IP Multimedia Subsystem (IMS); Multimedia telephony; Media handling and interaction".
- [144] 3GPP TS 26.141: "IP Multimedia System (IMS) Messaging and Presence; Media formats and codecs".
- [145] 3GPP TS 23.214: "Architecture enhancements for control and user plane separation of EPC nodes; Stage 2".
- [146] 3GPP TS 26.346: "Multimedia Broadcast/Multicast Service (MBMS); Protocols and codecs".
- [147] 3GPP TS 23.501: "System Architecture for the 5G System; Stage 2".

---

## 3 Definitions and abbreviations

In addition to the abbreviations given in the remainder of this clause others are listed in TR 21.905 [1a].

The definitions of the entities of the mobile system are given in the next clause.

### 3.1 Public Land Mobile Network (PLMN)

A Public Land Mobile Network (PLMN) is established and operated by an administration or Recognized Private Operating Agency (RPOA) for the specific purpose of providing land mobile telecommunications service services to the public. A PLMN may be regarded as an extension of networks (e.g. ISDN, corporate and public PDNs, etc.); it is a collection of MSCs areas in CS domain and SGSN areas for GPRS and SGSN or MME areas for EPC in PS domain within a common numbering plan (e.g. same National Destination Code) and a common routing plan. The MSCs are the functional interfaces between the fixed networks and a PLMN for call set-up in CS domain. The GGSN and the SGSN are the functional interfaces between the fixed networks and a PLMN for packet transmission in GPRS PS domain. In case of EPC PS Domain, the PDN GW, Serving-GW and the SGSN and the MME are the functional interfaces between the fixed networks and a PLMN for packet transmission.

Functionally the PLMNs may be regarded as independent telecommunications entities even though different PLMNs may be interconnected through the ISDN/PSTN and PDNs for forwarding of calls or network information. A similar type of interconnection may exist for the interaction between the MSCs/SGSNs/MMEs of one PLMN.

### 3.2 Core Network (CN) and Access Network (AN)

The PLMN infrastructure is logically divided into a Core Network (CN) and an Access Network (AN) infrastructures, as defined in TS 23.101 [11a] and TS 23.110 [11b]. The CN is logically divided into a CS domain, a PS domain and an IM subsystem, as defined in next clause. The AN are GERAN (also called BSS for GSM), UTRAN (also called RNS), E-UTRAN, as defined in clause "The Access Network".

### 3.3 Circuit Switched (CS) and Packet Switched (PS) Domains

The CN is constituted of a Circuit Switched (CS) domain and a Packet Switched (PS) domain (which includes GPRS and EPC). These two domains differ by the way they support user traffic, as explained below.

These two domains are overlapping, i.e. they contain some common entities. A PLMN can implement only one domain or both domains.

### 3.3.1 CS Domain

The CS domain refers to the set of all the CN entities offering "CS type of connection" for user traffic as well as all the entities supporting the related signalling. A "CS type of connection" is a connection for which dedicated network resources are allocated at the connection establishment and released at the connection release.

The entities specific to the CS domain are: MSC, GMSC, VLR. All the other CN entities defined in clause 4 "The basic entities of the mobile system" and not defined as PS domain specific entities (see following clause) are common to the CS and to the PS domains. In case of E-UTRAN access, there is no support for CS Domain.

### 3.3.2 PS Domain

The PS domain refers to the set of all the CN entities offering "PS type of connection" for user traffic as well as all the entities supporting the related signalling. A "PS type of connection" transports the user information using autonomous concatenation of bits called packets: each packet can be routed independently from the previous one.

The entities specific to the PS domain are the GPRS specific entities, i.e. SGSN and GGSN and EPS specific entities, i.e. PDN GW, S-GW, MME, SGSN. All the other CN entities defined in clause "4 The basic entities of the mobile system" and not defined as CS domain specific entities (see previous clause) are common to the CS and to the PS domains.

### 3.3a IP Multimedia subsystem (IMS)

The IM subsystem comprises all CN elements for provision of IP multimedia services comprising audio, video, text, chat, etc. and a combination of them delivered over the PS domain. The entities related to IMS are CSCF, MGCF, MRF, etc. as defined in the stage 2 of the IM subsystem TS 23.228 [34]. See TS 22.228 [27] for some service examples of IMS.

## 3.4 Location register

To enable communication to a mobile station the network must know where this mobile station is located. This information is stored in a function named location register.

The location register is handled by the following entities.

- The Home Location Register (HLR).

The Home Location Register (HLR) is the location register to which a mobile subscriber is assigned for record purposes such as subscriber information. For EPS, the HLR functionality is provided via HSS.

- The Visitor Location Register (VLR).

The Visitor Location Register (VLR) is the location register for Circuit Switched (CS) services, other than the HLR, used by an MSC to retrieve information for, e.g. handling of calls to or from a roaming mobile station currently located in its area.

- The Serving GPRS Support Node (SGSN).

The location register function in the SGSN stores subscription information and location information for Packet Switched (PS) services for each subscriber registered in the SGSN.

The SGSN is needed only in a PLMN which supports PS Domain with GERAN or UTRAN access.

- The Gateway GPRS Support Node (GGSN).

The location register function in the GGSN stores subscriber information and routing information (needed to tunnel packet data traffic destined for a GPRS MS to the SGSN where the MS is registered) for each subscriber for which the GGSN has at least one PDP context active.

The GGSN is needed only in a PLMN which supports GPRS with GERAN or UTRAN access.

- The Mobility Management Entity (MME).

The location register function in the MME stores subscription information and location information for Packet Switched (PS) services for each subscriber registered in the MME for EPS.

- The Packet Data Network Gateway (PDN GW).

The location register function in the PDN GW stores subscriber information and routing information (needed to tunnel packet data traffic destined for an EPS UE to the Serving GW, where the UE is registered in the MME, in the SGSN or in the 3GPP AAA server in case of non-3GPP access) for each subscriber for which the PDN GW has at least one PDN connection active.

## 3.5 Cell

The cell is an area of radio coverage identified by a Base station identification as defined in TS 23.003 [3].

## 3.6 Base Station Controller (BSC) area

The Base Station Controller (BSC) area is an area of radio coverage consisting of one or more cells controlled by one BSC. The boundaries of a BSC area and a location area are independent; a location area may span the boundary between BSC area and a BSC area may span the boundary between location areas.

## 3.7 Radio Network Controller (RNC) area

The Radio Network Controller (RNC) area is an area of radio coverage consisting of one or more cells controlled by one RNC. The boundaries of a RNC area and a location area are independent; a location area may span the boundary between RNC area and a RNC area may span the boundary between location areas.

## 3.8 Location Area (LA)

The Location Area (LA) is defined as an area in which a mobile station may move freely without updating the VLR. A location area includes one or several GERAN/UTRAN cells.

## 3.9 Routing Area (RA)

The Routing Area (RA) is defined as an area in which a mobile station, in certain operation modes, may move freely without updating the SGSN. A routing area includes one or several GERAN/UTRAN cells. A RA is always contained within a location area.

### 3.9a Tracking Area (TA)

A Tracking Area (TA) includes one or several E-UTRAN cells. The network allocates a list with one or more TAs to the UE. In certain operation modes, the UE may move freely in all TAs of the list without updating the MME.

## 3.10 MSC area

The MSC area is the part of the network covered by an MSC. An MSC area may consist of one or several location areas. An MSC area may also consist of one or several BSC areas.

## 3.11 VLR area

The VLR area is the part of the network controlled by a VLR. A VLR area may consist of one or several MSC areas.

## 3.12 SGSN area

The SGSN area is the part of the network served by an SGSN. An SGSN area may consist of one or several routing areas. An SGSN area may also consist of one or several BSC areas. There need not be a one to one relationship between SGSN area and MSC/VLR area.

## 3.13 Zones for Regional Subscription

A PLMN operator may define a number of regional subscription areas, each of which is a subset of the service area for an unrestricted mobile subscriber. A regional subscription area may be contained within the service area of a single PLMN, or may lie within the service areas of two or more PLMNs. Each regional subscription area consists of one or more zones; each zone is contained within the service area of a PLMN.

The definition of a mobile subscriber's regional subscription area is stored within the HLR/HSS per National Destination Code(s) (NDC) of a PLMN and is transferred to the VLRs and/or SGSNs/MMEs of that PLMN. The VLR and/or SGSN/MME evaluates this information to extract the restricted or accessible MSC and/or SGSN/MME areas and location areas to which the mobile subscriber is allowed to roam. The VLR and/or SGSN/MME inform the HLR/HSS if an entire MSC and/or SGSN/MME area is restricted.

Zones for Regional Subscription and their handling are defined in TS 23.003 [3], TS 23.008 [5] and TS 29.002 [26] and TS 29.272 [86] for EPC.

## 3.14 Service area

The service area is defined as an area in which a mobile subscriber can be reached by another (mobile or fixed) subscriber without the subscriber's knowledge of the actual location of the mobile station within the area. A service area may consist of several PLMNs. One service area may consist of one country, be a part of a country or include several countries. The location registration system associated with each service area must thus contain a list of all mobile stations located within that service area.

## 3.15 Group call area

The group call area is a predefined area composed of one or a number of cells to which a particular Voice Group Call Service (VGCS) or Voice Broadcast Service (VBS) call is distributed. The composition of a group call area is predefined in the network. The group call area may include cells of more than one MSC area and cells of more than one PLMN.

### 3.15a MME Area

The MME area is the part of the network served by an MME. An MME area consists of one or several Tracking Areas. All cells served by an eNodeB are included in an MME Area. There is no one to one relationship between an MME Area and an MSC/VLR area. Multiple MMEs may have the same MME Area as described in clause "Pool-area". MME Areas may overlap each other.

## 3.16 Pool-area

A pool area is an area where Intra Domain Connection of RAN Nodes to Multiple CN Nodes is applied. Within a pool-area an MS may roam without need to change the serving Core Network (CN) node. A pool-area is served by one or more CN nodes in parallel.

## 3.17 Serving GW Service Area

A Serving GW Service Area is the part of the network served by single Serving GW. Serving GW Service Areas consist of one or several complete Tracking Areas. All cells served by an eNodeB are included in an Serving GW Service Area. Serving GW Service Areas may overlap each other. There is no one to one relationship between an MME Area and a Serving GW Service Area.

---

## 4 The basic entities of the mobile system

To provide the mobile service as it is defined, it is necessary to introduce some specific functions. These functional entities can be implemented in different equipments or gathered. In any case, exchanges of data occur between these entities.

Entities in the mobile system can be either implemented in a monolithic way where user data are stored within the entity itself (or in an external entity via non standard interfaces) or according to the User Data Convergence (UDC) concept (see TS 23.335 [120]) where the entity becomes a so-called user-dataless Application Front End (AFE). Application Front Ends access, via the Ud reference point, a User Data Repository (UDR), which stores the relevant user data managed by the applications. Unless explicitly stated otherwise, this document describes entities in its monolithic form, e.g. stating that user data are stored in the HSS. If however the UDC concept applies, user data are actually stored in the UDR and managed by one or several Application Front Ends, so that user data may be shared among the different Application Front Ends, allowing several AFEs of the same application type (e.g. HSS) to serve the same user at any given time.

For the 5G System, see clause 4a.38.

### 4.1 The Core Network (CN) entities

#### 4.1.1 Entities common to the PS and CS domains

##### 4.1.1.1 The Home Subscriber Server (HSS)

The HSS is the master database for a given user. It is the entity containing the subscription-related information to support the network entities actually handling calls/sessions.

A Home Network may contain one or several HSSs: it depends on the number of mobile subscribers, on the capacity of the equipment and on the organisation of the network.

As an example, the HSS provides support to the call control servers in order to complete the routing/roaming procedures by solving authentication, authorisation, naming/addressing resolution, location dependencies, etc.

The HSS is responsible for holding the following user related information:

- User Identification, Numbering and addressing information;
- User Security information: Network access control information for authentication and authorization;
- User Location information at inter-system level: the HSS supports the user registration, and stores inter-system location information, etc.;
- User profile information.

The HSS also generates User Security information for mutual authentication, communication integrity check and ciphering.

Based on this information, the HSS also is responsible to support the call control and session management entities of the different Domains and Subsystems (defined in section 3.3 and 3.3a) of the operator as shown in figure 0-a.

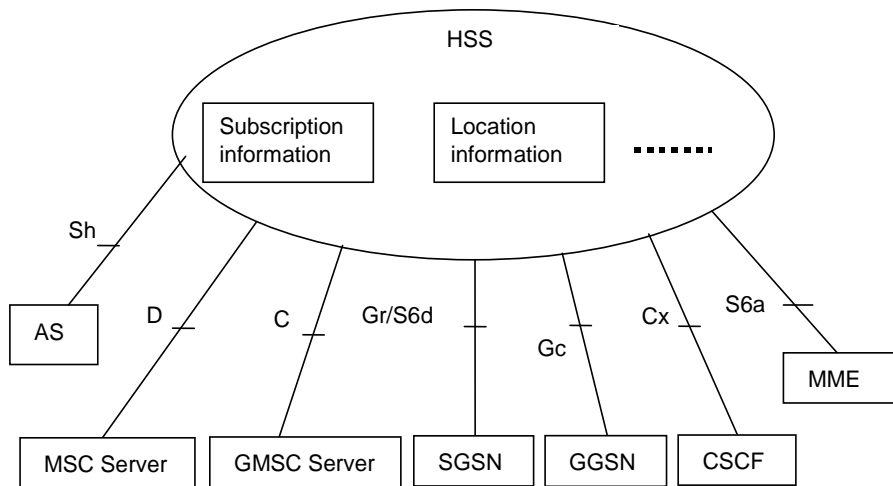

**Figure 0-a: Example of a Generic HSS structure and basic interfaces**

The HSS may integrate heterogeneous information, and enable enhanced features in the core network to be offered to the application & services domain, at the same time hiding the heterogeneity.

The HSS consists of the following functionalities:

- IP multimedia functionality to provide support to control functions of the IM subsystem such as the CSCF. It is needed to enable subscriber usage of the IM CN subsystem services. This IP multimedia functionality is independent of the access network used to access the IM CN subsystem.
- The subset of the HLR/AUC functionality required by the PS Domain (GPRS and EPC).
- The subset of the HLR/AUC functionality required by the CS Domain, if it is desired to enable subscriber access to the CS Domain or to support roaming to legacy GSM/UMTS CS Domain networks.

The organisation of the subscriber data is outlined in TS 23.008 [5]. It also indicates which numbers, addresses and identifiers specified in TS 23.003 [3] are stored in HSS.

#### 4.1.1.1.1 The Home Location Register (HLR)

The HLR is shown in the Reference Architecture up to and including Rel-4.

The HLR can be considered a subset of the HSS that holds the following functionality:

- The functionality required to provide support to PS Domain entities such as the SGSN, MME and GGSN, through the Gr, S6a, S6d and Gc interfaces and the 3GPP AAA Server for EPS in case of non-3GPP access via SWx and for the I-WLAN through the D'/Gr' interface. It is needed to enable subscriber access to the PS Domain services.
- The functionality required to provide support to CS Domain entities such as the MSC/MSC server and GMSC/GMSC server, through the C and D interfaces. It is needed to enable subscriber access to the CS Domain services and to support roaming to legacy GSM/UMTS CS Domain networks.

#### 4.1.1.1.2 The Authentication Centre (AuC)

The AuC is shown in the Reference Architecture up to and including Rel-4.

The AuC can be considered a subset of the HSS that holds the following functionality for the CS Domain and PS Domain:

- The AuC is associated with an HLR and stores an identity key for each mobile subscriber registered with the associated HLR. This key is used to generate security data for each mobile subscriber:
  - data which are used for mutual authentication of the International Mobile Subscriber Identity (IMSI) and the network;

- a key used to check the integrity of the communication over the radio path between the mobile station and the network;
- a key used to cipher communication over the radio path between the mobile station and the network.
- The AuC communicates only with its associated HLR over a non-standardised interface denoted the H-interface. The HLR requests the data needed for authentication and ciphering from the AuC via the H-interface, stores them and delivers them to the VLR and SGSN and MME which need them to perform the security functions for a mobile station.

#### 4.1.1.1.3 HSS logical functions

This section provides a high level and not exhaustive description of HSS functionality.

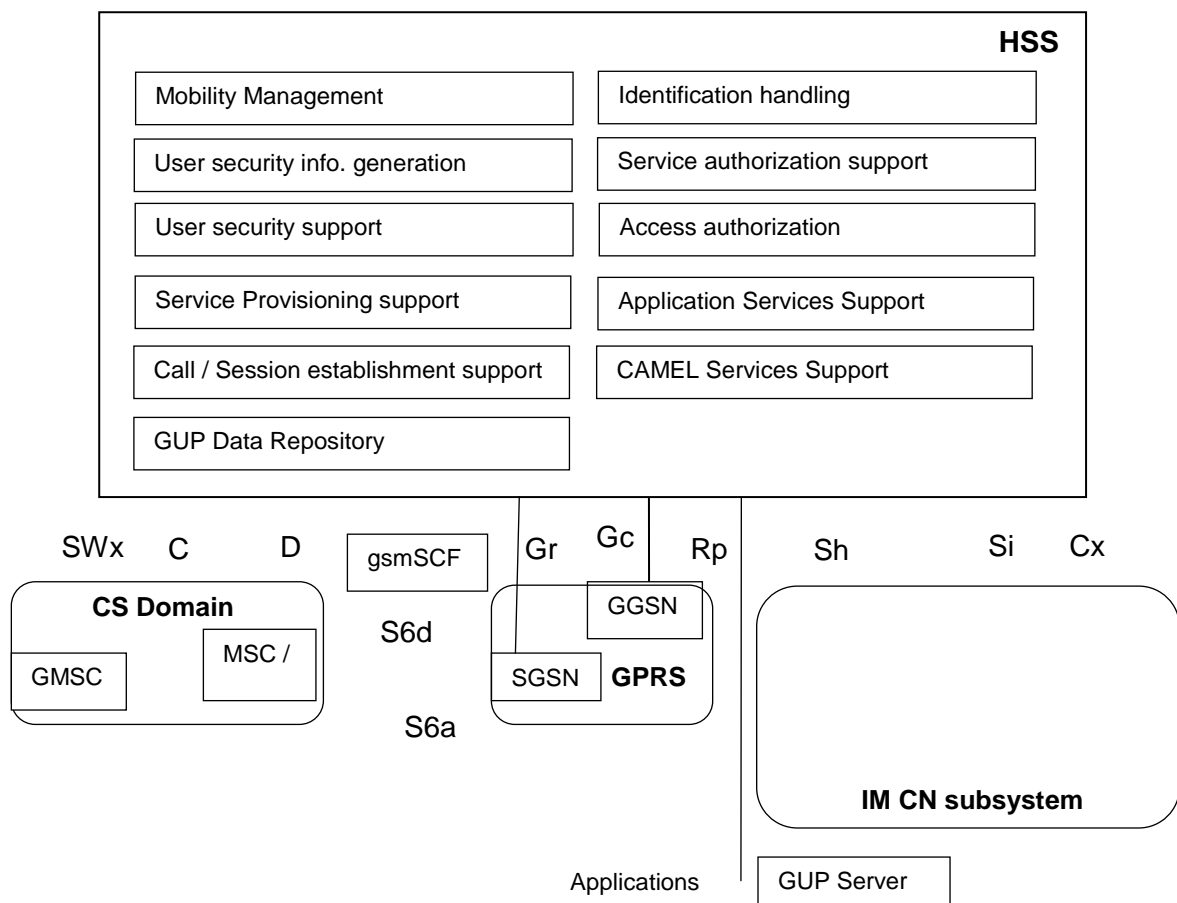

**Figure 0.b: HSS logical functions**

- **Mobility Management**  
This function supports the user mobility through CS Domain, PS Domain and IM CN subsystem.
- **Call and/or session establishment support**  
The HSS supports the call and/or session establishment procedures in CS Domain, PS Domain and IM CN subsystem. For terminating traffic, it provides information on which call and/or session control entity currently hosts the user.
- **User security information generation**
- **The HSS generates user authentication, integrity and ciphering data for the CS and PS Domains and for the IM CN subsystem. User security support**

The HSS supports the authentication procedures to access CS Domain, PS Domain and IM CN subsystem services by storing the generated data for authentication, integrity and ciphering and by providing these data to the appropriate entity in the CN (i.e. MSC/VLR, SGSN, MME, 3GPP AAA Server or CSCF).

- User identification handling

The HSS provides the appropriate relations among all the identifiers uniquely determining the user in the system: CS Domain, PS Domain and IM CN subsystem (e.g. IMSI and MSISDNs for CS Domain; IMSI, MSISDNs and IP addresses for PS Domain, private identity and public identities for IM CN subsystem).

- Access authorisation

The HSS authorises the user for mobile access when requested by the MSC/VLR, SGSN, MME, 3GPP AAA Server or CSCF, by checking that the user is allowed to roam to that visited network.

- Service authorisation support

The HSS provides basic authorisation for MT call/session establishment and service invocation. Besides, the HSS updates the appropriate serving entities (i.e., MSC/VLR, SGSN, MME, 3GPP AAA Server, CSCF) with the relevant information related to the services to be provided to the user.

- Service Provisioning Support

- The HSS provides access to the service profile data for use within the CS Domain, PS Domain and/or IM CN subsystem. Application Services and CAMEL Services Support (for GERAN and UTRAN access).

The HSS communicates with the SIP Application Server and the OSA-SCS to support Application Services in the IM CN subsystem. It communicates with the IM-SSF to support the CAMEL Services related to the IM CN subsystem. The IMS CAMEL subscription data may be transferred to the IM-SSF AS using Sh reference point in addition to the Si reference point. The HSS communicates with the gsmSCF to support CAMEL Services in the CS Domain and GPRS PS Domain (for GERAN and UTRAN access).

**Editor's Note: CAMEL support for GERAN/UTRAN via EPS (i.e. for S4 SGSN) is FFS.**

- GUP Data Repository

The HSS supports the storage of IM CN Subsystem user related data, and provides access to these data through the Rp reference point as described in TS 23.240 [71].

#### 4.1.1.2 The Visitor Location Register (VLR)

A mobile station roaming in an MSC area or within a GERAN/UTRAN pool-area is controlled by a Visitor Location Register. When a Mobile Station (MS) enters a new location area it starts a registration procedure. An MSC in charge of that area notices this registration and transfers to a Visitor Location Register the identity of the location area where the MS is situated. If this MS is not yet registered in the VLR, the VLR and the HLR exchange information to allow the proper handling of CS calls involving the MS.

A VLR may be in charge of one or several MSC areas.

The VLR contains also the information needed to handle the calls set-up or received by the MSs registered in its data base (for some supplementary services the VLR may have to obtain additional information from the HLR). The following elements are included:

- the International Mobile Subscriber Identity (IMSI);
- the Mobile Station International ISDN number (MSISDN);
- the Mobile Station Roaming Number (MSRN), see TS 23.003 [3] for allocation principles;
- the Temporary Mobile Station Identity (TMSI), if applicable;
- the Local Mobile Station Identity (LMSI), if used;
- the location area where the mobile station has been registered;

- the identity of the SGSN where the MS has been registered. Only applicable to PLMNs supporting GPRS and which have a Gs interface between MSC/VLR and SGSN;
- the last known location and the initial location of the MS;
- the identity of the MME where the MS has been registered. Only applicable to PLMNs supporting EPC and CS Fallback and which have a SGs interface between MSC/VLR and MME.

The VLR also contains supplementary service parameters attached to the mobile subscriber and received from the HLR. The organisation of the subscriber data is outlined in TS 23.008 [5].

#### 4.1.1.3 (void)

#### 4.1.1.4 The Equipment Identity Register (EIR)

The Equipment Identity Register (EIR) in the GSM system is the logical entity which is responsible for storing in the network the International Mobile Equipment Identities (IMEIs), used in the GERAN/UTRAN/E-UTRAN system.

The equipment is classified as "white listed", "grey listed", "black listed" or it may be unknown as specified in TS 22.016 [2] and TS 29.002 [26].

This functional entity contains one or several databases which store(s) the IMEIs used in the system.

The mobile equipment may be classified as "white listed", "grey listed" and "black listed" and therefore may be stored in three separate lists.

An IMEI may also be unknown to the EIR.

An EIR shall as a minimum contain a "white list" (Equipment classified as "white listed").

See also TS 22.016 [2] on IMEI.

#### 4.1.1.5 SMS Gateway MSC (SMS-GMSC)

The SMS Gateway MSC (SMS-GMSC) acts as an interface between a Short Message Service Centre and the PLMN, to allow short messages to be delivered to mobile stations from the Service Centre (SC).

The choice of which MSCs can act as SMS Gateway MSCs is a network operator matter (e.g. all MSCs or some designated MSCs).

#### 4.1.1.6 SMS Interworking MSC (SMS-IWMSC)

The SMS Interworking MSC acts as an interface between the PLMN and a Short Message Service Centre (SC) to allow short messages to be submitted from Mobile Stations to the SC.

The choice of which MSCs can act as SMS Interworking MSCs is a network operator matter (e.g. all MSCs or some designated MSCs).

#### 4.1.1.7 Subscription Locator Function (SLF)

The SLF:

- Is queried by the I-CSCF during the Registration and Session Setup to get the name of the HSS containing the required subscriber specific data. Furthermore the SLF is also queried by the S-CSCF during the Registration.
- Is queried by the AS in conjunction with the Sh interface operation to get the name of the HSS containing the required subscriber specific data.
- Is queried by the 3GPP AAA server to get the name of the HSS containing the required subscriber specific data.
- Is accessed via the Dx interface by the CSCF, via the Dh interface by the AS, and via the Dw interface by the 3GPP AAA Server.

The SLF is not required in a single HSS environment. An example for a single HSS environment is a server farm architecture. Use of SLF is not required when AS are configured/managed to use pre-defined HSS.

## 4.1.2 Entities of the CS domain

### 4.1.2.1 The Mobile-services Switching Centre (MSC)

The Mobile-services Switching Centre (MSC) constitutes the interface between the radio system and the fixed networks. The MSC performs all necessary functions in order to handle the circuit switched services to and from the mobile stations.

In order to obtain radio coverage of a given geographical area, a number of BSS and/or RNS are normally required; i.e. each MSC would thus have to interface to one or more BSS(s) and/or RNS(s). In addition several MSCs may be required to cover a country.

When Intra Domain Connection of RAN Nodes to Multiple CN Nodes is applied, all the MSCs serving a pool-area share the responsibility to serve the MSs located in the pool-area. All these MSCs interface to all the BSS(s) and/or RNS(s) forming the pool-area.

The Mobile-services Switching Centre is an exchange, which performs all the switching and signalling functions for mobile stations located in a geographical area designated as the MSC area. When Intra Domain Connection of RAN Nodes to Multiple CN Nodes is applied, one or more MSCs serve a pool-area, but each individual MS is served by only one out of these MSCs, as described in TS 23.236 [65]. The main difference between a MSC and an exchange in a fixed network is that the MSC has to take into account the impact of the allocation of radio resources and the mobile nature of the subscribers and has to perform in addition, at least the following procedures:

- procedures required for the location registration (see TS 23.012 [7]);
- procedures required for handover (see TS 23.009 [6]).

NOTE: When this improves the readability (e.g. when dealing with inter-releases handover), the term 2G-MSC can be used to refer to an MSC Release 98 or prior, and the term 3G-MSC can be used to refer to an MSC Release 99 or later.

When needed, the MSC can be implemented in two different entities: the MSC Server, handling only signalling, and the CS-MGW, handling user's data. A MSC Server and a CS-MGW make up the full functionality of a MSC.

The CS fallback enabled MSC supports the following additional functions according to TS 23.272 [81]:

- Maintaining SGs association towards MME for EPS/IMSI attached UE;
- Supporting SMS procedures according to CS Fallback.

#### 4.1.2.1.1 MSC Server

The MSC Server mainly comprises the call control (CC) and mobility control parts of a MSC.

The MSC Server is responsible for the control of mobile originated and mobile terminated CC CS Domain calls. It terminates the user-network signalling and translates it into the relevant network – network signalling. The MSC Server also contains a VLR to hold the mobile subscriber's service data and CAMEL related data.

The MSC Server controls the parts of the call state that pertain to connection control for media channels in a CS-MGW.

An MSC Server which has been enhanced for SRVCC provides the following functions as needed for support of SRVCC according to TS 23.216 [83]:

- Handling the Relocation Preparation procedure requested for the voice component from MME via Sv interface;
- Invoking the session transfer procedure from IMS to CS ;
- Coordinating the CS Handover and session transfer procedures;
- Handling the MAP\_Update\_Location procedure without it being triggered from the UE.

If a MSC Server is enhanced for IMS Centralized Services (as defined in TS 23.292 [110]), it is responsible for the CS to IMS interworking, and it terminates the user-network signalling received over the CS access (A/Iu and E interface) and translates it into SIP signalling in IMS and vice versa.

#### 4.1.2.1.2 Circuit Switched - Media Gateway Function (CS-MGW)

NOTE: In this document the term Media Gateway Function (MGW) is used when there is no need to differentiate between the CS domain entity and the IP Multimedia CN Subsystem entity. When referring specifically to the CS domain entity the term CS-MGW is used. When referring specifically to the IP Multimedia CN Subsystem entity, the term IMS-MGW is used.

This component is PSTN/PLMN transport termination point for a defined network and interfaces UTRAN with the core network over Iu.

A CS-MGW may terminate bearer channels from a switched circuit network and media streams from a packet network (e.g. RTP streams in an IP network). Over Iu, the CS-MGW may support media conversion, bearer control and payload processing (e.g. codec, echo canceller, conference bridge) for support of different Iu options for CS services (AAL2/ATM based as well as RTP/UDP/IP based).

The CS-MGW:

- Interacts with MGCF, MSC server and GMSC server for resource control.
- Owns and handles resources such as echo cancellers etc.
- May need to have Codecs.

The CS-MGW will be provisioned with the necessary resources for supporting UMTS/GSM transport media. Further tailoring (i.e. packages) of the H.248 [52] may be required to support additional Codecs and framing protocols, etc.

The CS-MGW bearer control and payload processing capabilities will also need to support mobile specific functions such as SRNS relocation/handover and anchoring. It is expected that current H.248 [52] standard mechanisms can be applied to enable this.

#### 4.1.2.2 The Gateway MSC (GMSC)

If a network delivering a call to the PLMN cannot interrogate the HLR, the call is routed to an MSC. This MSC will interrogate the appropriate HLR and then route the call to the MSC where the mobile station is located. The MSC which performs the routing function to the actual location of the MS is called the Gateway MSC (GMSC).

The acceptance of an interrogation to an HLR is the decision of the operator.

The choice of which MSCs can act as Gateway MSCs is for the operator to decide (i.e. all MSCs or some designated MSCs).

If the call is a voice group/broadcast call, it is routed directly from the GMSC to the VBS/VGCS Anchor MSC, based on information (VBS/VGCS call reference) contained in the dialled number (see also TS 43.068 [41] and TS 43.069 [42]).

**Editor's note:** There is a need to consider possibilities that call incoming to the PLMN may be routed to entities other than the GMSC, e.g., for networks that do not deploy CS domain.

When needed, the GMSC can be implemented in two different entities: the GMSC Server, handling only signalling, as defined below, and the CS-MGW, defined above. A GMSC Server and a CS-MGW make up the full functionality of a GMSC.

##### 4.1.2.2.1 Gateway MSC Server (GMSC Server)

The GMSC server mainly comprises the call control and mobility control parts of a GMSC.

##### 4.1.2.3 The Interworking Function (IWF)

The Interworking Function (IWF) is a functional entity associated with the MSC. The IWF provides the functionality necessary to allow interworking between a PLMN and the fixed networks (ISDN, PSTN and PDNs). The functions of

the IWF depend on the services and the type of fixed network. The IWF is required to convert the protocols used in the PLMN to those used in the appropriate fixed network. The IWF may have no functionality where the service implementation in the PLMN is directly compatible with that at the fixed network. The interworking functions are described in TS 29.007 [31].

### 4.1.3 Entities of the GPRS PS domain

The UTRAN/GERAN PS-domain (or GPRS) Support Nodes (GSN) are the Gateway GSN (GGSN) and the Serving GSN (SGSN). They constitute the interface between the radio system and the fixed networks for packet switched services. The GSN performs all necessary functions in order to handle the packet transmission to and from the mobile stations.

#### 4.1.3.1 Serving GPRS Support Node (SGSN)

The location register function in the SGSN stores two types of subscriber data needed to handle originating and terminating packet data transfer:

- subscription information:
  - the IMSI;
  - one or more temporary identities;
  - zero or more PDP addresses.
- location information:
  - depending on the operating mode of the MS, the cell or the routing area where the MS is registered;
  - the VLR number of the associated VLR (if the Gs interface is implemented);
  - the GGSN address of each GGSN for which an active PDP context exists.

The SGSN provide support for Direct Tunnel functions as specified in TS 23.060 [9a].

The organisation of the subscriber data in the SGSN is defined in TS 23.008 [5] and TS 23.060 [9a].

The procedures for information transfer between the SGSN, the GGSN, the VLR and the HLR are defined in TS 23.016 [39] and TS 23.060 [9a].

NOTE: When this improves the readability (e.g. when dealing with inter-releases handover), the term 2G-SGSN can be used to refer to a SGSN Release 98 or prior, and the term 3G-SGSN can be used to refer to a SGSN Release 99 or later.

The SGSN provides support for SRVCC functions as specified in TS 23.216 [83].

#### 4.1.3.2 Gateway GPRS Support Node (GGSN)

The location register function in the GGSN stores subscriber data received from the HLR and the SGSN. There are two types of subscriber data needed to handle originating and terminating packet data transfer:

- subscription information:
  - the IMSI;
  - zero or more PDP addresses.
- location information:
  - the SGSN address for the SGSN where the MS is registered.

The organisation of the subscriber data in the GGSN is defined in TS 23.008 [5] and TS 23.060 [9a].

The procedures for information transfer between the GGSN, the SGSN and the HLR are defined in TS 23.016 [39] and TS 23.060 [9a].

#### 4.1.3.3 Void

### 4.1.4 Entities of the EPC PS Domain

#### 4.1.4.1 MME

MME is the control plane entity within EPS supporting functions as listed below. For detailed functional role of MME, see specifications TS 23.401 [76], TS 23.402 [77] and TS 36.300 [78].

Mobility Management,

- NAS signalling and security;
- Inter CN node signalling for mobility between 3GPP access networks;
- Tracking Area list management;
- PDN GW and Serving GW selection;
- SGSN selection for handovers to 2G or 3G 3GPP access networks;
- Roaming ;
- Authentication;
- Bearer management functions including dedicated bearer establishment.
- Lawful Interception of signalling traffic.

In order to support 3GPP2 access, MME supports:

- HRPD access node selection and maintenance for handovers to HRPD;
- Transparent transfer of HRPD signalling messages and transfer of status information between E-UTRAN and HRPD access;
- Transparent transfer of RIM signalling messages between E-UTRAN and HRPD access;

The procedures for information transfer between the SGSN, the MME and the HSS are defined in TS 23.401 [76] and TS 23.060 [9a].

The CS fallback enabled MME supports the following additional functions according to TS 23.272 [81]:

- Deriving a VLR number and LAI out of the TAI
- Maintaining of SGs association towards MSC/VLR for EPS/IMSI attached UE
- Initiating IMSI detach at EPS detach
- Initiating paging procedure towards eNodeB when MSC pages the UE for CS services
- Supporting SMS procedures for CS Fallback.
- Support CS Fallback interface and related functions for 1xRTT CDMA access.

When the MME supports the interworking to 3GPP CS, the MME supports the following functions as specified in TS 23.216 [83]:

- Performing the PS bearer splitting function by separating the voice PS bearer from the non-voice PS bearers.
- Handling the non-voice PS bearers handover with the target cell as according to Inter RAT handover procedure as defined in TS 23.401 [76].
- Initiating the SRVCC handover procedure for handover of the voice component to the target cell.

- Coordinating PS handover and SRVCC handover procedures when both procedures are performed,
- support interworking and SRVCC related functions for 1xRTT CDMA access.

#### 4.1.4.2 Gateways

##### 4.1.4.2.1 Serving GW

The Serving GW is the gateway which terminates the interface towards E-UTRAN.

For each UE associated with the EPS, at a given point of time, there is a single Serving GW. For detailed S-GW functions, see TS 23.401 [76] and TS 23.402 [77].

Connectivity to a GGSN is not supported.

The functions of the Serving GW include:

- the local Mobility Anchor point for inter-eNodeB handover;
- Mobility anchoring for inter-3GPP mobility;
- ECM-IDLE mode downlink packet buffering and initiation of network triggered service request procedure;
- Lawful Interception;
- Packet routing and forwarding;
- Transport level packet marking in the uplink and the downlink;  
Accounting on user and QCI granularity for inter-operator charging;
- A local non-3GPP anchor for the case of roaming when the non-3GPP IP accesses connected to the VPLMN;
- Event reporting (change of RAT, etc.) to the PCRF;
- Uplink and downlink bearer binding towards 3GPP accesses as defined in TS 23.203 [73];
- Uplink bearer binding verification with packet dropping of "misbehaving UL traffic";
- Mobile Access Gateway (MAG) functions if PMIP-based S5 or S8 is used;
- Support necessary functions in order for enabling GTP/PMIP chaining functions.

The Serving GW can be split into SGW-C and SGW-U, which jointly provide above functionalities. The functional split between SGW-C and SGW-U are defined in TS 23.214 [145].

##### 4.1.4.2.2 PDN GW

The PDN GW is the gateway which terminates the SGi interface towards the PDN.

If a UE is accessing multiple PDNs, there may be more than one PDN GW for that UE, however a mix of S5/S8 connectivity and Gn/Gp connectivity is not supported for that UE simultaneously.

The PDN GW provides PDN connectivity to both GERAN/UTRAN only UEs and E-UTRAN capable UEs using any of E-UTRAN, GERAN or UTRAN. The PDN GW provides PDN connectivity to E-UTRAN capable UEs using E-UTRAN only over the S5/S8 interface. The PDN GW may also provide PDN connectivity to UEs using non-3GPP access networks with the procedures defined in TS 23.402 [77].

For detailed PDN GW functions, see TS 23.401 [76] and TS 23.402 [77].

PDN GW functions include:

- Per-user based packet filtering (by e.g. deep packet inspection);
- Lawful Interception;

- UE IP address allocation;
- Transport level packet marking in the uplink and downlink, e.g. setting the DiffServ Code Point, based on the QCI of the associated EPS bearer;
- UL and DL service level charging, gating control, rate enforcement as defined in TS 23.203 [73];
- UL and DL rate enforcement based on APN-AMBR;
- DL rate enforcement based on the accumulated MBRs of the aggregate of SDFs with the same GBR QCI (e.g. by rate policing/shaping);
- DHCPv4 (server and client) and DHCPv6 (client and server) functions;

Additionally the PDN GW includes the following functions for the GTP-based S5/S8/S2a/S2b:

- UL and DL bearer binding as defined in TS 23.203 [73];
- UL bearer binding verification;

The PDN GW functions also includes user plane anchor for mobility between 3GPP access and non-3GPP access. It supports:

- A LMA function for PMIPv6, if PMIP-based S5 or S8, or if PMIP based S2a or PMIP based S2b is used;
- A DSMIPv6 Home Agent, if S2c is used;
- Allocation of GRE key, which is used to encapsulate uplink traffic to the PDN GW on the PMIP-based S5/S8, or PMIP based S2a or PMIP based S2b interface;
- A MIPV4 Home Agent, if S2a with MIPv4 FA CoA mode is used.
- GPRS Tunnelling Protocol for the control plane and the user plane to provide PDN connectivity to UEs using non-3GPP accesses, if GTP based S2a or GTP based S2b is used.

The PDN GW can be split into PGW-C and PGW-U, which jointly provide above functionalities. The functional split between PGW-C and PGW-U are defined in TS 23.214 [145].

#### 4.1.4.2.3 Local GW (L-GW)

A Local GW is a gateway towards the IP networks (e.g. residential/enterprise networks, Internet).

For detailed Local GW functions, see TS 23.401 [76] and TS 23.060 [9a].

#### 4.1.4.3 SGSN

In addition to the functions described for GPRS, for EPC SGSN functions include:

- Inter EPC node signalling for mobility between 2G/3G and E-UTRAN 3GPP access networks;
- PDN and Serving GW selection: the selection of S GW/PDN GW by the SGSN is as specified for the MME;
- MME selection for handovers to E-UTRAN 3GPP access network.

For details, see TS 23.401 [76] and TS 23.060 [9a].

#### 4.1.4.4 Trusted and Untrusted Non-3GPP Access Network

Trusted and Untrusted Non-3GPP Access Networks are IP access networks that use access technology whose specification is out of the scope of 3GPP.

Whether a Non-3GPP IP access network is Trusted or Untrusted is not a characteristic of the access network.

In non-roaming scenario it is the HPLMN's operator decision if a Non-3GPP IP access network is used as Trusted or Untrusted Non-3GPP Access Network.

In roaming scenario, the HSS/3GPP AAA Server in HPLMN makes the final decision of whether a Non-3GPP IP access network is used as Trusted or Untrusted non-3GPP Access Network. The HSS/3GPP AAA Server may take the VPLMN's policy and capability returned from the 3GPP AAA Proxy or roaming agreement into account.

For details, see TS 23.402 [77].

#### 4.1.4.5 ePDG

The functionality of ePDG includes the following:

- Functionality defined for the PDG in TS 23.234 [67] for the allocation of a remote IP address as an IP address local to the ePDG which is used as CoA when S2c is used;
- Functionality for transportation of a remote IP address as an IP address specific to a PDN when S2b is used;
- Routing of packets from/to PDN GW (and from/to Serving GW if it is used as local anchor in VPLMN) to/from UE; if GTP based S2b is used, this includes routing of uplink packets based on the uplink packet filters in the TFTs assigned to the S2b bearers of the PDN connection;
- Routing of downlink packets towards the SWu instance associated to the PDN connection;
- De-capsulation/Encapsulation of packets for IPsec and, if network based mobility (S2b) is used, for GTP or PMIP tunnels;
- Mobile Access Gateway (MAG) for PMIPv6 if PMIP based S2b is used;
- Tunnel authentication and authorization (termination of IKEv2 signalling and relay via AAA messages);
- Local mobility anchor within untrusted non-3GPP access networks using MOBIKE (if needed);
- Transport level packet marking in the uplink;
- Enforcement of QoS policies based on information received via AAA infrastructure;
- Lawful Interception.

For details, see TS 23.402 [77].

#### 4.1.4.6 3GPP AAA Server

The 3GPP AAA Server is located at the HPLMN and provides support for non-3GPP Access users with services like Authentication, Authorisation and location management services in order to get access to EPS. It also contains necessary user related information in order to grant access to non-3GPP access. It also coordinates the information needed to support mobility between 3GPP and non-3GPP accesses such as coordination of PDN GW information. It interacts with HSS to maintain consistent information for users supporting mobility and service continuity between 3GPP and non-3GPP access. For details, see TS 23.402 [77].

#### 4.1.4.7 3GPP AAA Proxy

The 3GPP AAA Proxy provides support for roaming non-3GPP Access users in the VPLMN necessary the Authentication, Authorisation and location management services in order to get access to EPS. It may also provide roaming related information for support of chaining scenarios as described in TS 23.402 [77]. If an S-GW is needed for non-3GPP access in the visited network, the 3GPP AAA proxy selects an S-GW for the UE during initial attach or handover attach.

#### 4.1.4.8 ANDSF

The ANDSF (which is an optional element in the architecture) contains data management and control functionality necessary to provide network discovery and selection assistance data as per operators' policy. The ANDSF is able to initiate data transfer to the UE, based on network triggers, and respond to requests from the UE. It provides functions such as inter-system mobility policy, access network discovery information.

The ANDSF in the subscriber's home operator network may interact with other databases such as the HSS user profile information residing in subscriber's home operator network. Details of such interaction with these databases are not described in this Release of the specifications. For details on ANDSF, see TS 23.402 [77].

NOTE: When the UE is roaming, how it discovers and interacts with the ANDSF is not specified in the specification of this release.

#### 4.1.5 Border Gateway (BG)

The Border Gateway (BG) is a gateway between a PLMN supporting GPRS/EPC and an external inter-PLMN backbone network used to interconnect with other PLMNs also supporting GPRS/EPC. The role of the BG is to provide the appropriate level of security to protect the PLMN and its subscribers.

The BG is only needed in PLMNs supporting GPRS and EPC.

### 4.2 The Access Network (AN) entities

Three different types of access network are used by the CN: the AN include GERAN (also called BSS), UTRAN (also called RNS) and E-UTRAN. The MSC (resp. SGSN) can connect to one of the following Access Network type or to both of them: BSS, RNS. The MME connects to the E-UTRAN.

The access technologies offered by the BSS are described in the 45-series of 3GPP specifications. The access technologies offered by the RNS (FDD, TDD) are described in the 25-series of 3GPP specifications. The access technologies offered by E-UTRAN (FDD, TDD) are described in the 36-series of 3GPP specifications.

#### 4.2.1 The Base Station System (BSS)

The Base Station System (BSS) is the system of base station equipments (transceivers, controllers, etc.) which is viewed by the MSC through a single A and/or Iu-CS interface as being the entity responsible for communicating with Mobile Stations in a certain area. Similarly, in PLMNs supporting GPRS, the BSS is viewed by the SGSN through a single Gb or Iu-PS interface. When Intra Domain Connection of RAN Nodes to Multiple CN Nodes is applied, a BSS may connect to several MSCs by several A and/or Iu-CS interfaces, and a BSS may connect to several SGSNs by several Gb and/or Iu-PS interfaces. The functionality for the A interface is described in TS 48.002 [14] and for the Gb interface in TS 23.060 [9a]. The functionality for the Iu-CS interface is described in TS 25.410 [14a] and for the Iu-PS interface in TS 23.060 [9a].

The radio equipment of a BSS may support one or more cells. A BSS may consist of one or more base stations. Where an Abis-interface is implemented, the BSS consists of one Base Station Controller (BSC) and one or more Base Transceiver Station (BTS). The split of functions between BSS and CN for a Iu interface is described in the 25-series of UMTS Technical Specifications.

The split of functions between BSS and CN for a A/Gb interface is described in the 48-series of GSM Technical Specifications. The split of functions between BSS and CN for a Iu interface is described in the 25-series of UMTS Technical Specifications.

NOTE: The mobile station shall operate using only the following modes:

- a A / G<sub>b</sub> mode**, e.g. for pre-Release 4 terminals, or for Release 4 terminals when connected to a BSS with no Iu interface towards the Core Network.
- b Iu mode** (i.e. Iu-CS and Iu-PS), e.g. for Release 4 terminals when connected to a BSS with Iu interfaces towards the Core Network.

No other modes (e.g. A/Iu-PS or Iu-CS/Gb) shall be allowed.

See also TS 43.051 [36].

##### 4.2.1.1 Base Station Controller (BSC)

A Base Station Controller (BSC) is a network component in the PLMN with the functions for control of one or more BTS.

#### 4.2.1.2 Base Transceiver Station (BTS)

A Base Transceiver Station (BTS) is a network component which serves one cell.

### 4.2.2 The Radio Network System (RNS)

The Radio Network System (RNS) is the system of base station equipments (transceivers, controllers, etc.) which is viewed by the MSC through a single Iu-interface as being the entity responsible for communicating with Mobile Stations in a certain area. Similarly, in PLMNs supporting GPRS, the RNS is viewed by the SGSN through a single Iu-PS interface. When Intra Domain Connection of RAN Nodes to Multiple CN Nodes is applied, an RNS may connect to several MSCs by several Iu-CS interfaces, and an RNS may connect to several SGSNs by several Iu-PS interfaces. The functionality for the Iu-CS interface is described in TS 25.410 [14a] and for the Iu-PS interface in TS 23.060 [9a]. The radio equipment of a RNS may support one or more cells. A RNS may consist of one or more base stations. The RNS consists of one Radio Network Controller (RNC) and one or more Node B.

The split of functions between RNS and CN is described in the 25-series of UMTS Technical Specifications.

#### 4.2.2.1 Radio Network Controller (RNC)

A Radio Network Controller (RNC) is a network component in the PLMN with the functions for control of one or more Node B.

#### 4.2.2.2 Node B

A Node B is a logical network component which serves one or more UTRAN cells.

### 4.2.3 Access Network elements for E-UTRAN

#### 4.2.3.1 E-UTRAN Node B (eNB)

An eNB is a logical network component which serves one or more E-UTRAN cells.

#### 4.2.3.2 Evolved UTRAN

The Evolved UTRAN (E-UTRAN) consists of eNBs, providing the E-UTRA user plane (PDCP/RLC/MAC/PHY) and control plane (RRC) protocol terminations towards the UE. The eNBs can be interconnected with each other by means of the X2 interface. The eNBs are connected by means of the S1 interface to the EPC (Evolved Packet Core), more specifically to the MME (Mobility Management Entity) by means of the S1-MME and to the Serving Gateway (S-GW) by means of the S1-U interface. The S1 interface supports a many-to-many relation between MMEs / Serving Gateways and eNBs.

The split of functions between eNB and EPC is described in the specifications TS 23.401 [76], TS 36.300 [78] and TS 36.401 [79].

The architecture defined using E-UTRAN can be further described as follows:

The E-UTRAN consists of set of eNBs connected to the EPC through the S1 interface.

An eNB can support FDD mode, TDD mode or dual mode operation.

## 4.3 The Mobile Station (MS)

The mobile station consists of the physical equipment used by a PLMN subscriber; it comprises the Mobile Equipment (ME) and the Subscriber Identity Module (SIM), called UMTS Subscriber Identity Module (USIM) for Release 99 and following. The ME comprises the Mobile Termination (MT) which, depending on the application and services, may support various combinations of Terminal Adapter (TA) and Terminal Equipment (TE) functional groups. These functional groups are described in TS 24.002 [12].

## 4.4 User Equipment (UE)

The User Equipment Allows a user access to network services. For the purpose of 3GPP specifications the interface between the UE and the network is the radio interface. A User Equipment can be subdivided into a number of domains, the domains being separated by reference points. Currently the User Equipment is subdivided into the UICC domain and the ME Domain. The ME Domain can further be subdivided into one or more Mobile Termination (MT) and Terminal Equipment (TE) components showing the connectivity between multiple functional groups.

---

### 4a The specific entities of the 3GPP system

The entities presented in this clause are dedicated to the provisioning of a given (set of) service(s). The fact that they are implemented or not in a given PLMN should have limited impact on all the other entities of the PLMN.

All the specific entities defined so far are located in the Core Network.

#### 4a.1 The Group Call Register (GCR) entity

The Group Call Register (GCR) is a register holding information about VGCS or VBS calls, the voice group or broadcast call attributes, respectively.

Voice group or broadcast call attributes are defined for a specific voice group or broadcast call reference and include the data required to configure the conference bridge for a VGCS or VBS call and other call related attributes.

The Group Call Register (GCR) shall hold for a related MSC area for each group ID and cell from which Voice Group Call Service (VGCS) or Voice Broadcast Service (VBS) calls can be established by mobile stations the voice group call reference or voice broadcast call reference to be used for a VGCS or VBS call to be established and an indication whether the originating MSC is the MSC responsible for that call.

If the originating MSC is not responsible for that call, the GCR shall hold the routing information identifying the MSC responsible for that call.

A GCR may be in charge of one or several MSC. Each MSC involved in a voice group or broadcast call requests its proper voice group or broadcast call attributes from its related GCR by use of the voice group or broadcast call reference.

The contents of each list related to requests of the MSC responsible for a voice group or broadcast call is as follows:

- a list of cells inside the MSC area of the requesting MSC into which the call is to be sent (part of the group call area);
- a list of other MSCs into which the call is to be sent;
- a list of identities of dispatchers to which a dedicated link is to be established;
- a list of identities of dispatchers which are allowed to initiate the voice group or broadcast call;
- a list of identities of dispatchers which are allowed to terminate the voice group or broadcast call;
- the length of time over which no activity is detected before the voice group call is automatically terminated;
- the default priority level related to the voice group or broadcast call if the eMLPP supplementary service applies;
- a flag indicating if acknowledgements are required for this voice group or broadcast call.

The contents of each list related to requests of an MSC not responsible for a voice group or broadcast call is as follows:

- a list of cells inside the MSC area of the requesting MSC into which the call is to be sent (part of the group call area).

More information is provided in TS 43.068 [41] and TS 43.069 [42].

## 4a.2 (void)

## 4a.3 The Location Services (LCS) entities

This section describes the Location Services entities found in the Core Network and Radio Access Network that support positioning methods for the UE/MS.

For further details on LCS in E-UTRAN, UMTS and GSM from system and core network point view, see TS 23.271 [56].

For further details on LCS in UTRAN, see TS 25.305 [10b].

For further details on LCS in GERAN, see TS 43.059 [10d].

For further details on user-plane LCS in E-UTRAN, see OMA SUPL [80]. For further details on control plane LCS for E-UTRAN see TS 36.305 [122].

### 4a.3.1 Location Services (LCS) entities in RAN

The RAN (E-UTRAN, UTRAN and GERAN) supports one or more UE/MS positioning methods to calculate the geographical position of the UE/MS and responds to the UE/MS location request received from the CN. For UTRAN and GERAN, the RAN may broadcast LCS assistance data to UEs/MSs under its coverage. In case this assistance data is ciphered, the ciphering key is provided by the CN to the UE/MS.

To support UE positioning methods, the RAN is made of several entities like:

**BSC/SRNC:** the BSC for GERAN and SRNC for UTRAN receive authenticated location requests from the CN:

- In UTRAN, the SRNC co-ordinates the positioning requests taking into account their priority and it selects the positioning method to fulfil the requested accuracy. It interfaces, when necessary, with the CRNC which mainly manages resources allocated to UE positioning operations and requests UE Positioning related measurements from its associated Node Bs and LMUs.
- In GERAN, the BSC passes the location request to the SMLC.

**SMLC:**

- The Serving Mobile Location Centre (SMLC) function can be part of the RNC or be a SAS (Stand-Alone SMLC) for UTRAN. The SMLC function can be part of the BSC or be in a separate SMLC server for GERAN.
- In UTRAN, the SMLC function provides assistance data to the RNC and acts as a location calculation server if the location estimates are not to be calculated in the RNC.
- In GERAN, the SMLC function co-ordinates the positioning request, schedules resources required to perform positioning of a mobile, and calculates the final location estimate and accuracy. The SMLC may control a number of LMUs.

**LMU:** The Location Measurement Unit (LMU) entity makes measurements for one or more positioning methods.

**Node B:** Node B is a network element of UTRAN that may provide measurement results for position estimation and makes measurements of radio signals.

**eNodeB:** The eNode B is a network element of E-UTRAN that may provide measurement results for position estimation and makes measurements of radio signals for a target UE and communicates these measurements to an E-SMLC.

**CBC:** The Cell Broadcast Centre, in GERAN, the SMLC function may interface a CBC in order to broadcast assistance data using existing cell broadcast capabilities.

For detail on Location services, entities and interfaces provided by E-UTRAN, see TS 36.305 [122].

For detail on Location services, entities and interfaces provided by UTRAN, see TS 25.305 [10b].

For detail on Location services, entities and interfaces provided by GERAN, see TS 43.059 [10d].

### 4a.3.2 Gateway Mobile Location Centre (GMLC)

The Gateway Mobile Location Centre (GMLC) is the first node an external Location Application accesses in the GSM PLMN. The GMLC performs registration authorization and requests routing information from the HLR/HSS. There may be more than one GMLC in a PLMN.

### 4a.3.3 Location Measurement Unit (LMU)

An LMU makes radio measurements to support one or more positioning methods.

Two types of LMU are defined:

- Type A LMU: accessed over the normal GSM air interface;
- Type B LMU: accessed over the base station to controller interface (Abis in GSM and Iub in UMTS).

A type A LMU is accessed exclusively over the GSM air interface (Um interface): there is no wired connection to any other network element.

In GSM, a type A LMU has a serving BTS and BSC that provide signalling access to a controlling SMLC. With an NSS based SMLC, a type A LMU also has a serving MSC and VLR and a subscription profile in an HLR. A type A LMU always has a unique IMSI and supports all radio resource and mobility management functions of the GSM air interface that are necessary to support signalling using an SDCCH to the SMLC. A type A LMU supports those connection management functions necessary to support LCS signalling transactions with the SMLC and may support certain call control functions of to support signalling to an SMLC using a circuit switched data connection.

In UTRAN, a type A LMU has signalling access to the SRNC. Type A LMU is not supported in UMTS release 1999.

In GSM, a Type B LMU is accessed over the Abis interface from a BSC. The LMU may be either a standalone network element addressed using some pseudo-cell ID or connected to or integrated in a BTS. Signalling to a Type B LMU is by means of messages routed through the controlling BSC for a BSS based SMLC or messages routed through a controlling BSC and MSC for an NSS based SMLC.

In UTRAN, a Type B LMU is accessed over the Iub interface from an RNC. The LMU may be either a standalone network element addressed using some pseudo-cell ID or connected to or integrated in a Node B.

### 4a.3.4 Evolved Serving Mobile Location Centre (E-SMLC)

For E-UTRAN, the Evolved Serving Mobile Location Centre (E-SMLC) is a server in the core network. The E-SMLC manages the support of different location services for target UEs, including positioning of UEs and delivery of assistance data to UEs. The E-SMLC may interact with the serving eNodeB for a target UE in order to obtain position measurements for the UE, including uplink measurements made by the eNodeB and downlink measurements made by the UE that were provided to the eNodeB as part of other functions such as for support of handover.

The E-SMLC may interact with a target UE in order to deliver assistance data if requested for a particular location service, to obtain a location estimate, or location related measurements, if that was requested.

For positioning of a target UE, the E-SMLC decides on the position methods to be used, based on factors that may include the LCS Client type, the required QoS, UE positioning capabilities, and eNode B positioning capabilities. The E-SMLC then invokes these positioning methods in the UE and/or serving eNode B. The positioning methods may yield a location estimate for UE-based position methods and/or positioning measurements for UE-assisted and network-based position methods. The E-SMLC may combine all the received results and determine a single location estimate for the target UE (hybrid positioning). Additional information like accuracy of the location estimate and velocity may also be determined.

## 4a.4 CAMEL entities

The entities of this clause support the CAMEL feature (Customised Applications for Mobile network Enhanced Logic). This feature provides the mechanisms to support services consistently independently of the serving network, as described in TS 22.078 [2c]. The following definitions are extracted from TS 23.078 [10c], which completely specifies CAMEL stage 2.

### 4a.4.1 GSM Service Control Function (gsmSCF)

A functional entity that contains the CAMEL service logic to implement Operator Specific Service. It interfaces with the gsmSSF, the gsmSRF and the HLR.

### 4a.4.2 GSM Service Switching Function (gsmSSF)

A functional entity that interfaces the MSC/GMSC to the gsmSCF. The concept of the gsmSSF is derived from the IN SSF, but uses different triggering mechanisms because of the nature of the mobile network.

### 4a.4.3 GSM Specialised Resource Function (gsmSRF)

A functional entity which provides various specialized resources. It interfaces with the gsmSCF and with the MSC. This entity is defined in ITU-T Q.1214 [11] with variations defined in TS 23.078 [10c].

### 4a.4.4 GPRS Service Switching Function (gprsSSF)

A functional entity that interfaces the SGSN to the gsmSCF. The concept of the gprsSSF is derived from the IN SSF, but uses different triggering mechanisms because of the nature of the mobile network.

## 4a.5 CBS-specific entities

The cell broadcast service (CBS) is a Teleservice which enables an Information Provider to submit short messages for broadcasting to a specified area within the PLMN. TS 23.041 [8] contains the technical realization of the service.

### 4a.5.1 Cell Broadcast Centre (CBC)

The CBC shall be responsible for the management of CBS messages and for determining the CBS delivery parameters of the BSS/RNS. The CBC may be connected to several BSCs/RNCs. The CBC is regarded to be integrated as a node into the core network.

NOTE: Whether it should be possible that an RNC is connected to at least two CBCs at the same time (the "normal" one as in GSM and a second one for LCS) is for further study and depends on the solution taken for LCS.

## 4a.6 Number Portability Specific entities

Two different solutions are defined to support Number Portability. The first one is an IN based solution and is described in the next clause. The second one is a "Signalling Relay" based solution described in next but one clause.

For details on MNP see TS 23.066 [40].

### 4a.6.1 IN-based solution: Number Portability Database (NPDB)

The Number Portability Database (NPDB) is the central element of the IN based solution for Mobile Number Portability (MNP). MNP is the ability for a mobile subscriber to change the GSM subscription network within a portability cluster (e.g. a country) whilst retaining his/her original MSISDN or MSISDNs.

The NPDB stores the table of correspondence between MSISDNs and Subscription networks. Upon request of the (gateway or visited) MSC, the NPDB retrieves from the MSISDN the Routing Number pointing out the Subscription network.

## 4a.6.2 Signalling Relay-based solution: Mobile Number Portability/Signalling Relay function (MNP-SRF)

The MNP-Signalling Relay Function (MNP-SRF) is the central element of the Signalling Relay based solution for Mobile Number Portability.

The MNP-SRF obtains the routing information from a NP database to identify the subscription network associated with a particular national MSISDN. Upon request from gateway MSC, the MNP-SRF may perform one of the following actions:

1. the MNP-SRF will reply back to the GMSC with the necessary routing information to route the call;
2. the message is relayed to the HLR;
3. the message is relayed to MNP-SRF in the subscription network.

For non-call related signalling (e.g. delivery of SMS), only cases 2 and 3 are applicable.

## 4a.7 IP Multimedia (IM) Core Network (CN) Subsystem entities

### 4a.7.1 Call Session Control Function (CSCF)

The CSCF can act as Proxy CSCF (P-CSCF), Serving CSCF (S-CSCF), Emergency CSCF (E-CSCF), or Interrogating CSCF (I-CSCF). The P-CSCF is the first contact point for the UE within the IM subsystem (IMS); the S-CSCF actually handles the session states in the network; the E-CSCF handles certain aspects of emergency sessions such as routing an emergency request to the correct emergency centre or PSAP; the I-CSCF is mainly the contact point within an operator's network for all IMS connections destined to a subscriber of that network operator, or a roaming subscriber currently located within that network operator's service area. Further definitions of the P-, S- and I-CSCF are provided in TS 23.228 [34]. Further definitions of the E-CSCF is provided in TS 23.167 [74].

### 4a.7.2 Media Gateway Control Function (MGCF)

The MGCF:

- Controls the parts of the call state that pertain to connection control for media channels in an IMS-MGW.
- Communicates with CSCF, BGCF, and circuit switched network entities.
- Determines the next hop depending on the routing number for incoming calls from legacy networks.
- Performs protocol conversion between ISUP/TCAP/SIP-I and the IM subsystem call control protocols.
- Out of band information received in MGCF may be forwarded to CSCF/IMS-MGW.

### 4a.7.3 IP Multimedia Subsystem - Media Gateway Function (IMS-MGW)

Note: In this document the term Media Gateway Function (MGW) is used when there is no need to differentiate between the CS domain entity and the IP Multimedia CN Subsystem entity. When referring specifically to the CS domain entity, the term CS-MGW is used. When referring specifically to the IP Multimedia CN Subsystem entity, the term IMS-MGW is used.

A IMS-MGW may terminate bearer channels from a switched circuit network and media streams from a packet network (e.g., RTP streams in an IP network). The IMS-MGW may support media conversion, bearer control and payload processing (e.g. codec, echo canceller, conference bridge), it:

- Interacts with the MGCF for resource control.

- Owns and handles resources such as echo cancellers etc.
- May need to have Codecs.

The IMS-MGW will be provisioned with the necessary resources for supporting UMTS/GSM transport media. Further tailoring (i.e. packages) of the H.248 [52] may be required to support additional Codecs and framing protocols, etc.

#### 4a.7.4 Multimedia Resource Function Controller (MRFC)

The MRFC:

- Controls the media stream resources in the MRFP.
- Interprets information coming from an AS and S-CSCF (e.g. session identifier) and control MRFP accordingly.
- Generates CDRs .

#### 4a.7.4a Multimedia Resource Function Processor (MRFP)

The MRFP:

- Controls bearers on the Mb reference point.
- Provides resources to be controlled by the MRFC.
- Mixes incoming media streams (e.g. for multiple parties).
- Sources media streams (for multimedia announcements).
- Processes media streams (e.g. audio transcoding, media analysis).
- Floor Control (i.e. manage access rights to shared resources in a conferencing environment).

#### 4a.7.4b Media Resource Broker (MRB)

The MRB supports the sharing of a pool of heterogeneous MRF resources by multiple heterogeneous applications. MRB assigns (and later releases) specific suitable MRF resources to calls as requested by the consuming applications, based on MRF attributes specified by the applications as well as other criteria.

The MRB may take the following kinds of information into account when assigning MRF resources to an application:

- the specific characteristics of the media resources required for the call or calls;
- the identity of the application;
- rules for allocating MRF resources across different applications;
- per-application or per-subscriber SLA or QoS criteria; and
- capacity models of particular MRF resources.

#### 4a.7.5 Void

#### 4a.7.6 Breakout Gateway Control Function (BGCF)

The Breakout Gateway control function (BGCF) determines the next hop for routing the SIP message. This determination may be based on information received in the signalling protocol, administrative information, and/or database access. For PSTN /CS Domain terminations, the BGCF determines the network in which PSTN/CS Domain breakout is to occur and - within the network where the breakout is to occur - selects the MGCF.

Details are described in TS 23.228 [34].

### 4a.7.7 Application Server (AS)

An Application Server (AS) i.e., SIP Application Server, OSA Application Server, or CAMEL IM-SSF, offers value added IM services and resides either in the user's home network or in a third party location. The third party could be a network or simply a stand-alone AS.

NOTE 1: The OSA Application Server does not directly interact with the IMS network entities but through the OSA Service Capability Servers (OSA SCS-s). Further information on OSA is provided in TS 22.127 [4].

NOTE 2: A SIP Application Server specified within 3GPP that supports IMS reference points (e.g. ISC, Sh, Ut), in support of an application, is considered as part of the IM CN subsystem. Examples of such ASs are SCC AS and TAS.

The AS (SIP Application Server and/or the OSA Service Capability Server and/or IM-SSF) can communicate with the HSS. The Sh and Si interfaces are used for this purpose.

The Serving-CSCF to AS interface is used to provide services residing in an AS. Two cases were identified:

- Serving-CSCF to an AS in Home Network.
- Serving-CSCF to an AS in a trusted External Network (e.g., Third Party or Visited). The S-CSCF does not provide authentication and security functionality for secure direct third party access to the IM Subsystem. The OSA framework provides a standardized way for third party access to the IM Subsystem.

The Interrogating-CSCF to AS interface is used to forward SIP requests destined to a Public Service Identity hosted by the AS directly to that AS.

The AS to MRFC interfaces are:

- Mr' , used for session control;
- Cr, used for media control.

The AS to MRB interface (Rc) is used by the AS to request that MRF resources with certain characteristics be assigned to a call.

An Application Server may influence and impact the SIP session on behalf of the services supported by the operator's network. An AS may host and execute services.

### 4a.7.8 Interconnection Border Control Function (IBCF)

An IBCF provides application specific functions at the SIP/SDP protocol layer in order to perform interconnection between two operator domains. It enables communication between IPv6 and IPv4 SIP applications. network topology hiding, controlling transport plane functions, screening of SIP signalling information, selecting the appropriate signalling interconnect and generation of charging data records. Details are described in TS 23.228 [34].

### 4a.7.9 Transition Gateway (TrGW)

A TrGW is located within the media path and controlled by an IBCF. It provides functions like network address/port translation and IPv4/IPv6 protocol translation. Details are described in TS 23.228 [34].

### 4a.7.10 Location Retrieval Function (LRF)

The LRF retrieves location information for the UE including, where required, interim location information, initial location and updated location information. The LRF may interact with a Routing Determination Function (RDF) in order to obtain routing information. The LRF may interact with a GMLC or other types of location server functions in order to obtain location information. Further definitions of the LRF is provided in TS 23.167 [74].

### 4a.7.11 Service Centralization and Continuity Application Server (SCC AS)

The SCC AS is an IMS Application that can provide functionality required to enable IMS Centralized Services as defined in TS 23.292 [110], and can provide IMS-based mechanisms for enabling service continuity of multimedia sessions as defined in TS 23.237 [111].

#### 4a.7.11a Emergency Access Transfer Function (EATF)

The EATF provides IMS-based mechanisms for enabling service continuity of IMS emergency sessions. It is a function in the serving (visited if roaming) IMS network, providing the procedures for IMS emergency session anchoring and PS to CS access transfer as defined in TS 23.237 [111].

#### 4a.7.12 Access Transfer Control Function (ATCF)

The ATCF is a function in the serving (visited if roaming) IMS network. It enables SRVCC Session Transfer mechanisms in the serving network for a UE. The SCC AS can provide Session Transfer mechanisms in the serving network, if an ATCF is present in the SIP registration path of the UE, as defined in TS 23.237 [111].

#### 4a.7.13 Access Transfer Gateway (ATGW)

The ATGW is a media function in the serving (visited if roaming) IMS network. It may anchor the media for enhanced SRVCC procedure as defined in TS 23.237 [111].

## 4a.8 Signalling Gateway Function (SGW)

The SGW performs the signalling conversion (both ways) at transport level between the SS7 based transport of signalling used in pre-Rel-4 networks, and the IP based transport of signalling possibly used in post-R99 networks (i.e. between Sigtran SCTP/IP and SS7 MTP). The SGW does not interpret the application layer (e.g. MAP, CAP, BICC, ISUP) messages but may have to interpret the underlying SCCP or SCTP layer to ensure proper routing of the signalling.

## 4a.9 Global Text Telephony Specific entities

Interworking between cellular text modem (CTM) and text telephony standards (e.g. V.18) used in external networks can be supported by three methods:

- Routing calls through a CTM Special resource function (CTM-SRF) in the core network. The CTM-SRF is linked in to the call path via CAMEL procedures. Depending on operator configuration the CTM-SRF may also be linked in to the call path for Emergency calls.
- A CTM / Text telephone converting function included along the speech call path selected by the network after an indication from the terminal that CTM is required.
- A CTM / Text telephone converting function included in all speech call paths.

Further information of the support for text telephony is found in TS 23.226 [37].

For further details of CTM, see TS 26.226 [38].

## 4a.10 Security Gateway (SEG)

The 3GPP system and its network domains shall be logically and physically divided into security domains in order to protect IP based control plane signalling. These security domains typically coincide with operator borders.

The interface between different security domains is protected by Security Gateways (SEGs). The SEGs are responsible for enforcing the security policy of a IP security domain towards other SEGs in the destination IP security domain. All NDS/IP traffic shall pass through a SEG before entering or leaving a security domain. For further details of SEG, see TS 33.210 [64].

## 4a.11 Application Function (AF)

The Application Function (AF) is an element offering applications that require the control of IP bearer resources or the control of flow based bearer charging. The AF is capable of communicating with the PCRF to transfer dynamic QoS-related service information and/or dynamic charging-related service information.

One example of an AF is the P-CSCF of the IM CN subsystem.

## 4a.12 Void

## 4a.13 3GPP/WLAN Interworking entities

### 4a.13.1 WLAN UE

A WLAN UE is the User Equipment using a UICC card utilized by a 3GPP subscriber to access the WLAN network for 3GPP interworking purpose.

### 4a.13.2 3GPP AAA Proxy

The 3GPP AAA Proxy in case of I-WLAN access as specified in TS 23.234 [67] represents a AAA proxying and filtering function and resides in the visited 3GPP network. It is involved in access and service authentication and authorization procedures of a WLAN UE.

### 4a.13.3 3GPP AAA Server

The 3GPP AAA server resides in the 3GPP network and in case of I-WLAN access as specified in TS 23.234 [67] is responsible for access and service authentication and authorization of a WLAN UE.

### 4a.13.4 WLAN Access Gateway (WAG)

The WLAN access gateway is a gateway between WLAN and 3GPP network. In the roaming case it resides in the visited 3GPP network, otherwise in the home 3GPP network. It provides filtering, policing and charging functionality for the traffic between WLAN UE and 3GPP network.

### 4a.13.5 Packet Data Gateway (PDG)

The Packet Data Gateway provides access to PS based services for a WLAN UE. It resides either in the home (for access to home services) or in the visited 3GPP network (for access to local services).

### 4a.13.6 Home Agent (HA)

The HA provides control and mobility function for service continuity between 3GPP WLAN Interworking system and 3GPP Systems. The HA terminates the HGi reference point towards the PDN as defined in TS 23.327 [112].

## 4a.14 Multimedia Broadcast Multicast Service (MBMS) specific entities

### 4a.14.1 General

The Multimedia Broadcast Multicast Service (MBMS) is a point-to-multipoint service in which data is transmitted from a single source entity to multiple recipients. TS 23.246 [70] contains the technical realization of the service.

## 4a.14.2 Broadcast-Multicast Service Centre (BM-SC)

The Broadcast-Multicast Service Centre provides functions for MBMS user service provisioning and delivery. It may serve as an entry point for content provider MBMS transmissions, used to authorise and initiate MBMS Bearer Services within the PLMN and can be used to schedule and deliver MBMS transmissions.

## 4a.14.3 MBMS-GW

The MBMS-GW provides functions in the EPS for controlling MBMS session initiation/modification/termination by the MBMS User Service and for providing delivery of IP Multicast datagrams from the SGi-mb reference point to downstream nodes in the MBMS Service Area with a specified quality of service.

## 4a.14.4 Multi-cell/multicast Coordination Entity (MCE)

The MCE is a functional entity providing functions for admission control and allocation of radio resources by E-UTRAN and for MBMS session control. See TS 36.300 [78].

## 4a.15 Void

## 4a.16 GUP Server

The GUP Server is a functional entity providing a single point of access to the Generic User Profile data of a particular subscriber. The architecture does not specify or limit the physical location of the GUP Server enabling flexibility in the implementations. For further details of the GUP Server, see TS 23.240 [71].

## 4a.17 Policy and Charging Rules Function (PCRF)

The Policy and Charging Rules Function (PCRF) acts as a policy decision point for policy and charging control of service data flows/applications and IP bearer resources. The PCRF selects and provides the applicable policy and charging control decision to the PCEF and, if applicable, application detection and control decision to the TDF or PCEF with application detection and control feature. When the Gxx interface applies, the PCRF maintains the correlation between the GW control session over Gxx interface and the IP-CAN session over Gx. The PCRF also acts as an information exchange relay between BBERF and PCEF to forward event triggers, which can't be transferred directly.

When the Sd interface applies, the PCRF maintains the correlation between the IP-CAN session and the TDF session. Events subscribed by the TDF are reported by the PCRF.

When S9a interface applies, the PCRF provides to the BPCF the UE/H(e)NB local IP address and UDP port number, the QoS rules and PCC rules over S9a interface. PCRF maintains the correlation between the GW control session over S9a interface and the IP-CAN session over Gx interface (if IP-CAN session over Gx interface is available).

When S15 interface applies, the PCRF provides dynamic QoS control policies to the BPCF for the purpose of allocation of QoS resources in the Fixed Broadband Access Network for HNB CS traffic.

PCRF is the policy and charging control element. PCRF functions are described in more detail in TS 23.203 [73].

In non-roaming scenario, there is only a single PCRF in the HPLMN associated with one UE's IP-CAN session.

In a roaming scenario with local breakout of traffic and/or when a Gxx interface applies there are two PCRFs associated with one UE's IP-CAN session:

- H-PCRF that resides within the H-PLMN;
- V-PCRF that resides within the V-PLMN.

A single logical PCRF entity may be deployed by means of multiple and separately addressable PCRFs in the PLMN. In this case, the PCRF discovery and selection is enabled by Diameter Routing Agency (DRA).

## 4a.18 Policy and Charging Enforcement Function (PCEF)

The Policy and Charging Enforcement Function (PCEF) acts as a policy enforcement point for policy and charging control of IP bearer resources.

This functional entity is located at the Gateway (e.g. GGSN in the GPRS case) and in the PDN GW for EPS).

The functionality of PCEF is described in TS 23.203 [73], TS 23.401 [76] and TS 23.402 [77].

## 4a.19 Support of Short Message Service over generic 3GPP Internet Protocol access (SMSIP) specific entities

### 4a.19.1 General

Support of Short Message Service over generic 3GPP Internet Protocol access (SMSIP) provide 3GPP SMS messaging services across any form of IP Connectivity Access Network. TS 23.204 [75] contains the technical realization of the service.

### 4a.19.2 IP-Short-Message-Gateway (IP-SM-GW)

The IP Short Message Gateway function is used for two functions: to deliver SMS messages over the IP network and to provide interworking between SMS users and Instant Messaging users. The interworking function translates between MAP or Diameter based signalling and SIP signalling to convey messages and responses between the two systems. Both functions are described in TS 23.204 [75].

## 4a.20 Subscription Profile Repository (SPR)

The SPR logical entity contains all subscriber/subscription related information needed for subscription-based policies and charging control by the PCRF.

## 4a.21 Service Data Flow Based Credit Control Function

The Service Data Flow Based Credit Control Function performs online credit control functions. It is a functional entity embedded in the Online Charging Function (OCF) within the Online Charging System. (OCS) as specified in TS 32.296 [108].

## 4a.22 Offline Charging System (OFCS)

The Offline Charging System is logically specified in TS 32.240 [85].

## 4a.23 Online Charging System (OCS)

The Online Charging System is specified in TS 32.296 [108].

## 4a.24 Bearer Binding and Event Reporting Function (BBERF)

The Bearer Binding and Event Reporting Function (BBERF) acts as a policy enforcement point for bearer binding, uplink bearer binding verification and event reporting to the PCRF when Gxx applies.

This function entity is located at a GW (e.g. S-GW in the 3GPP access with PMIP based S5/S8 case, HSGW in the HRPD case, A-GW in the non- 3GPP access when PMIP or DSMIPv6 based mobility is used, ePDG with PMIP based S2b or Untrusted S2c case if Gxb\* applies).

The BBERF in the ePDG supports only reporting of the UE's Local IP address and UDP port number to the PCRF. Bearer binding and bearer binding verification functions are not supported.

## 4a.25 Home (e)NodeB entities

### 4a.25.1 Home NodeB Subsystem (HNS)

The Home NodeB Subsystem (HNS) consists of a Home NodeB (HNB), a Home NodeB Gateway (HNB-GW) and optionally a Local GW (L-GW). The Home NodeB Subsystem appears as an RNS to the core network and is connected by means of the Iu-CS interface to the MSC and by means of the Iu-PS interface to the SGSN.

A Home NodeB is a Customer Premises Equipment (CPE) offering UTRAN coverage, further details can be found in TS 25.467 [114].

A Home NodeB Gateway is the gateway through which the Home NodeB accesses the core network, more details can be found in TS 25.467 [114].

A Local GW is a gateway towards the IP networks (e.g. residential/enterprise networks, Internet) associated with the Home NodeB, more details can be found in TS 23.060 [9a]. The Local GW can be collocated with the Home NodeB or can be a standalone GW (with Serving GW and Local GW collocated) residing in the Local Network.

### 4a.25.2 Home eNodeB Subsystem (HeNS)

The Home eNodeB Subsystem (HeNS) consists of a Home eNodeB (HeNB), optionally a Home eNodeB Gateway (HeNB-GW) and optionally a Local GW (L-GW). The Home eNodeB Subsystem is connected by means of the S1 interface to the EPC (Evolved Packet Core), more specifically to the MME (Mobility Management Entity) by means of the S1-MME interface and to the Serving Gateway (S-GW) by means of the S1-U interface.

A Home eNodeB is a Customer-Premises Equipment (CPE) offering E-UTRAN coverage, further details can be found in TS 36.300 [78].

A Home eNodeB Gateway is an optional gateway through which the Home eNodeB accesses the core network, more details can be found in TS 36.300 [78].

A Local GW is a gateway towards the IP networks (e.g. residential/enterprise networks, Internet) associated with the Home eNodeB, more details can be found in TS 23.401 [76]. The Local GW can be collocated with the Home eNodeB or can be a standalone GW (with Serving GW and Local GW collocated) residing in the Local Network.

### 4a.25.3 CSG List Server

The CSG List Server provisions the Allowed CSG list and the Operator CSG list on the UE using the OTA procedures defined in TS 31.102 [118] or the OMA DM procedures defined in TS 24.285 [117].

The Allowed CSG list and the Operator CSG list are applicable to both UTRAN and E-UTRAN CSG cells for HNB and HeNB respectively.

### 4a.25.4 CSG Subscriber Server (CSS)

The CSS is the entity in the VPLMN storing and managing CSG subscription-related information for roaming UEs to enable VPLMN Autonomous CSG Roaming (see TS 22.220 [130]).

The CSS is responsible for holding the following user related information:

- User Identification;
- CSG membership granted to the subscriber during his stay in the VPLMN, i.e. list of CSG IDs and associated expiration dates;
- User Location information: the CSS stores the location information of the subscriber for subsequent update of the CSG subscription information at the MME, SGSN and VLR upon subscription change.

The CSS consists of the following functionalities:

- download of the CSG subscription information upon request from the serving MME, SGSN and VLR, through the S7a, S7d, Gm and Hm interfaces, to enable roaming subscribers to access to the PS and CS Domain services via CSG cells;
- service provisioning, including updating the appropriate serving entities (i.e. MME, SGSN and VLR) with modifications of the the CSG membership granted to the subscriber.

The organisation of the subscriber data is outlined in TS 23.008 [5]. It also indicates which numbers and identifiers specified in TS 23.003 [3] are stored in the CSS.

## 4a.26 Application Front Ends (AFE)

When the User Data Convergence (UDC) architecture is applied, certain functional entities keep the application logic, but do not locally store user data permanently. Examples of such functional entities are HLR/HSS/AuC and Application Servers. These data-less functional entities are known in the UDC architecture as Application Front Ends. The application that is handled by an AFE determines the type of AFE, e.g. HLR-FE or HSS-FE. The reference points between the Front Ends and the core and service layers are not affected by the UDC architecture. More information on Application Front Ends can be found in TS 23.335 [120].

## 4a.27 User Data Repository (UDR)

The UDR is a functional entity that acts as a single logical repository storing user data. The user-related data traditionally stored in the HSS/HLR/AuC, Application Servers, etc., are now stored in the UDR. UDR facilitates the share and provisioning of user-related data. The UDR provides a unique reference point to Application Front Ends such as HSS/HLR/AuC/AS Front Ends. This reference point is named Ud. More information on the UDR can be found in TS 23.335 [120].

## 4a.28 Traffic Detection Function (TDF)

The Traffic Detection Function (TDF) is a functional entity that performs application detection and control.

The functional description of the TDF is in TS 23.203 [73].

The TDF can be split into TDF-C and TDF-U, which jointly provide TDF functionalities. The functional split between TDF-C and TDF-U are defined in TS 23.214 [145].

## 4a.29 Specific entities to facilitate communications with packet data networks and applications

### 4a.29.1 Machine Type Communication-InterWorking Function (MTC-IWF)

The Machine Type Communication-InterWorking Function (MTC-IWF) is a functional entity that acts as an interface between the PLMN and a Services Capability Server (SCS) to provide specific MTC functionalities in the PLMN such as device triggering.

The functional description of the MTC-IWF is in TS 23.682 [132].

### 4a.29.2 Machine Type Communication- Authentication, Authorization and Accounting (MTC-AAA)

The Machine Type Communication-Authentication, Authorization and Accounting (MTC-AAA) is a functional entity that translates an IMSI to the external identifier(s) of the user.

The functional description of the MTC-AAA is in TS 23.682 [132].

### 4a.29.3 Service Capability Exposure Function (SCEF)

The Service Capability Exposure Function (SCEF) is a functional entity that provides a means to securely expose the services and capabilities provided by 3GPP network interfaces.

The functional description of the SCEF is in TS 23.682 [132].

### 4a.30 TCP Proxy Function

When TCP is being used, TCP connection is between a TCP client and a TCP server as defined in RFC793 [138]. A TCP Proxy Function splits a TCP connection such that it terminates the TCP connection received from the UE and establishes a corresponding TCP connection to the other end system in packet data network.

Note: The TCP Proxy Function can be deployed in a GGSN/PGW or as an external function beyond SGi/Gi. The TCP Proxy is deployed such that it is transparent to the UE and its mobility.

The implementation and necessary protocols to realize the functions related to TCP Proxy Function are outside the scope of 3GPP specifications.

### 4a.31 Specific entities for Packet Switched Streaming (PSS) Service

#### 4a.31.1 Packet Switched Streaming Service Server (PSS Server)

PSS Server provides the 3GPP packet switched streaming service based on the IETF RTSP/SDP and/or HTTP standards, with 3GPP extensions.

The description of the PSS Server is detailed in TS 26.233 [139].

### 4a.32 Specific entities for Group Communication System Enablers for LTE (GCSE\_LTE)

#### 4a.32.1 Group Communication Service Application Server (GCS AS)

The GCS AS transfers application data, e.g. media data and/or application signalling, to a group of UEs either over MBMS Bearer Services using the Broadcast Mode of MBMS (TS 23.246 [70]); or over EPS Bearers (TS 23.401 [76]); or over both MBMS and EPS bearer services. GCS AS uses the MB2 reference point to deliver data to UEs over MBMS Bearer Services.

The description of the GCS AS is detailed in TS 23.468 [140].

### 4a.33 Specific entities for Proximity-based Services (ProSe)

#### 4a.33.1 ProSe Function

The ProSe Function is the logical function that is used for network related actions required for ProSe. The ProSe Function plays different roles for each of the features of ProSe. In this version of the specification it is assumed that there is only one logical ProSe Function in each PLMN that supports Proximity Services.

The description of the ProSe Function is detailed in TS 23.303 [141].

## 4a.34 RAN Congestion Awareness Function (RCAF)

A RAN Congestion Awareness Function (RCAF) is a functional entity which reports RAN User Plane Congestion Information to the PCRF to enable the PCRF to take the RAN user plane congestion status into account for policy decisions.

The functional description of the RCAF can be found in TS 23.203 [73], TS 23.401 [76] and TS 23.060 [9a].

## 4a.35 Traffic Steering Support Function (TSSF)

The Traffic Steering Support Function (TSSF) is a functional entity which receives traffic steering control information from the PCRF for the purpose of traffic steering in the (S)Gi-LAN.

The functional description of the TSSF can be found in TS 23.203 [73].

## 4a.36 Specific entities for mission critical communication services

### 4a.36.1 Mission Critical Push To Talk Application Server (MCPTT AS)

MCPTT AS transfers mission critical application data, e.g. media data and/or application signalling, to a group of UEs over on-network services. MCPTT is provided either via on-network services and/or off-network services as specified in TS 23.179 [142].

The description of the MCPTT AS with the network functional models and the reference points is detailed in TS 23.179 [142].

## 4a.37 Packet Flow Description Function (PFDF)

The Packet Flow Description Function (PFDF) is a repository which stores Packet Flow Descriptions (PFDs) that can be managed, i.e. added, updated, or removed, by the SCS/AS (3rd party service provider) via the SCEF. The functional description of the PFDF can be found in TS 23.682 [132].

## 4a.38 5G System architecture

The Stage 2 system architecture for the 5G System is specified in TS 23.501 [147].

---

# 5 Configuration of a Public Land Mobile Network

## 5.1 Basic configuration

The basic configuration of a Public Land Mobile Network (PLMN) supporting GPRS and the interconnection to the PSTN/ISDN and PDN is presented in figure 1 and figure 1a. Whereas the basic configuration of a Public Land Mobile Network (PLMN) supporting PS Domain (both GPRS and EPC) and the interconnection to the PSTN/ISDN and PDN is presented in figure 1b. This configuration presents signalling and user traffic interfaces which can be found in a PLMN. Implementations may be different: some particular functions may be gathered in the same equipment and then some interfaces may become internal interfaces.

In the basic configuration presented in figure 1, all the functions are considered implemented in different equipments. Therefore, all the interfaces within PLMN are external. Interfaces A and Abis are defined in the 48-series of Technical Specifications. Interfaces Iu, Iur and Iub are defined in the 25.4xx-series of Technical Specifications. Interfaces B, C, D, E, F and G need the support of the Mobile Application Part of the signalling system No. 7 to exchange the data necessary to provide the mobile service. No protocols for the H-interface and for the I-interface are standardized. All the GPRS-specific interfaces (G- series) are defined in the 23-series, 24-series and 29-series of Technical Specifications. Interfaces Mc, Nb, and Nc are defined in TS 23.205 [43] and in the 29-series of Technical Specifications. The specifications for E-UTRAN interfaces S1 and X2 are specified in TS 36.4xx and NAS protocol is

specified in TS 24.301 [89] series of specifications. The interfaces S6a/d/S13 are specified in the specifications TS 29.272 [86]. The EPC specific S1/3/4/5/8/10/11/12/ series are specified in TS 29.274 [90] for GTP based protocols and for PMIP based S5/8 interfaces are specified in TS 29.275 [93].

From this configuration, all the possible 3GPP access PLMN organisations can be deduced. In the case when some functions are contained in the same equipment, the relevant interfaces become internal to that equipment.

The configuration possibilities when using non-3GPP access technologies using EPS is not part of the scope of this specification. The architecture and details for non-3GPP access and mobility and interworking with non-3GPP access are described in TS 23.402 [77] and the interfaces and protocols are specified in 3GPP 24-series and 29-series of specifications..

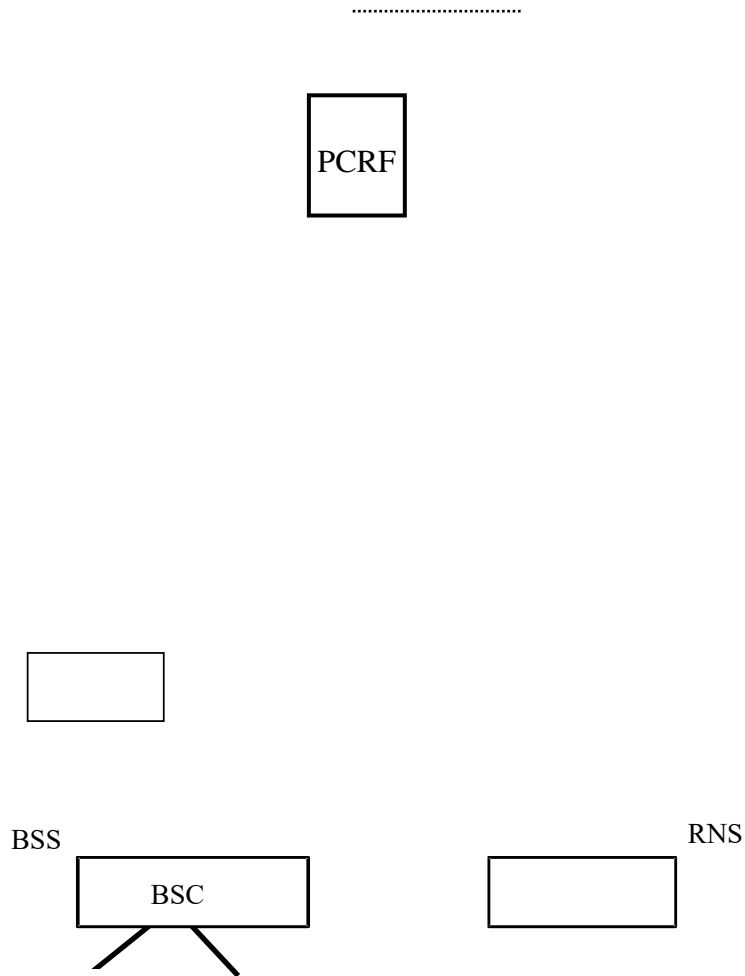

Legend:

Bold lines: interfaces supporting user traffic;

Dashed lines: interfaces supporting signalling.

NOTE 1: The figure shows direct interconnections between the entities. The actual links may be provided by an underlying network (e.g. SS7 or IP); this needs further studies.

NOTE 2: When the MSC and the SGSN are integrated in a single physical entity, this entity is called UMTS MSC (UMSC).

NOTE 3: A (G)MSC server and associated CS-MGW can be implemented as a single node: the (G)MSC.

NOTE 4: The Gn interface (between two SGSNs) is also part of the reference architecture, but is not shown for layout purposes only.

**Figure 1: Basic Configuration of a PLMN supporting CS and PS services (using GPRS) and interfaces**

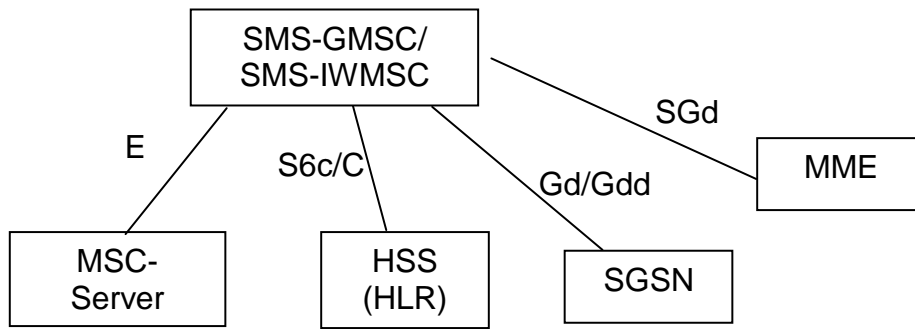

Figure 1a: Configuration for Short Message Service



## 5.2 Configuration of LCS entities

### 5.2.1 Configuration of LCS entities for GERAN

The configuration of LCS entities for GERAN is presented in figure 2. In the figure, all the functions are considered implemented in different logical nodes. If two logical nodes are implemented in the same physical equipment, the relevant interfaces may become internal to that equipment.

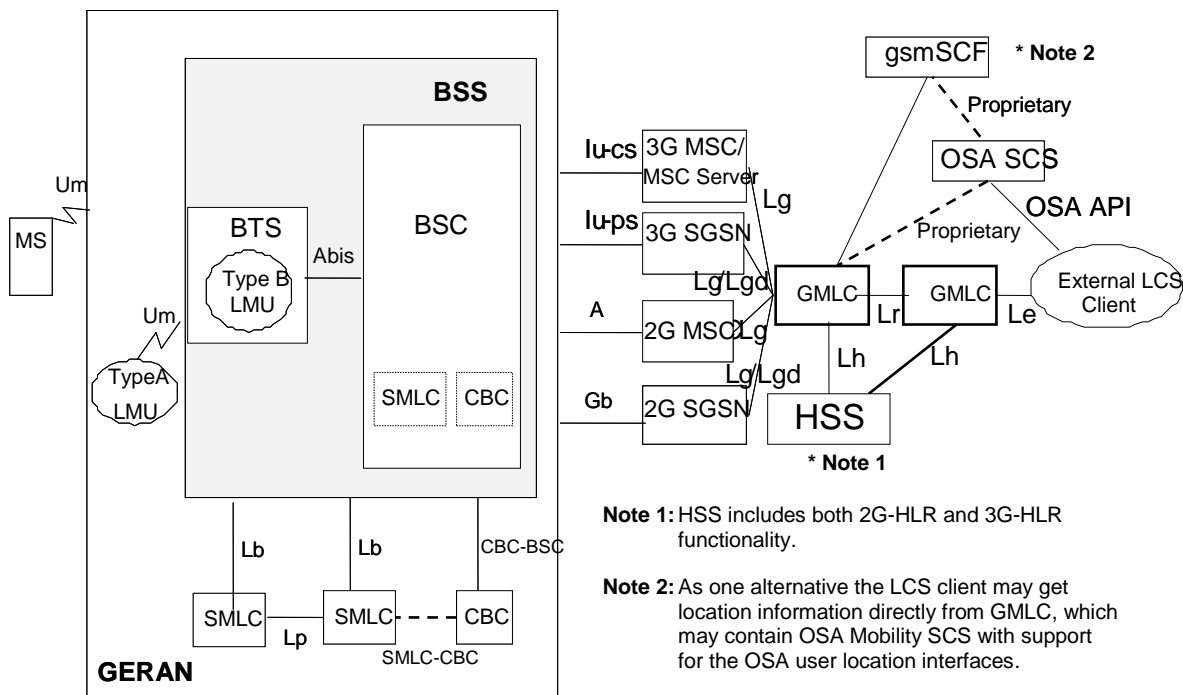

NOTE: Lgd interface is applicable only for an SGSN supporting EPS based interfaces and protocols.

**Figure 2: Configuration of LCS entities for a GERAN PLMN**

### 5.2.2 Configuration of LCS entities for UTRAN

The basic configuration of UTRAN LCS is presented in figure 3. The SMLC functionality is integrated in SRNC or, in case a Stand-Alone SMLC entity (SAS) is present, split between SRNC and SMLC.

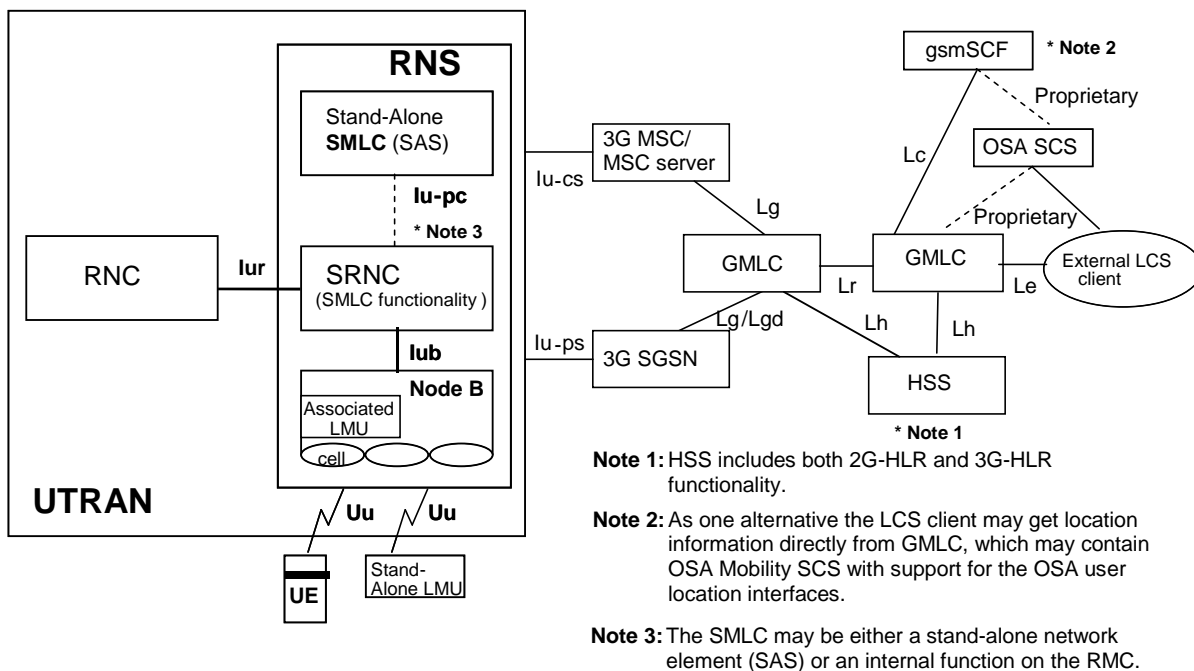

NOTE: Lgd interface is applicable only for an SGSN supporting EPS based interfaces and protocols.

**Figure 3: Configuration of LCS entities for a UTRAN PLMN**

### 5.2.3 Configuration of LCS entities for E-UTRAN

The basic configuration of E-UTRAN LCS is presented in figure 3a.

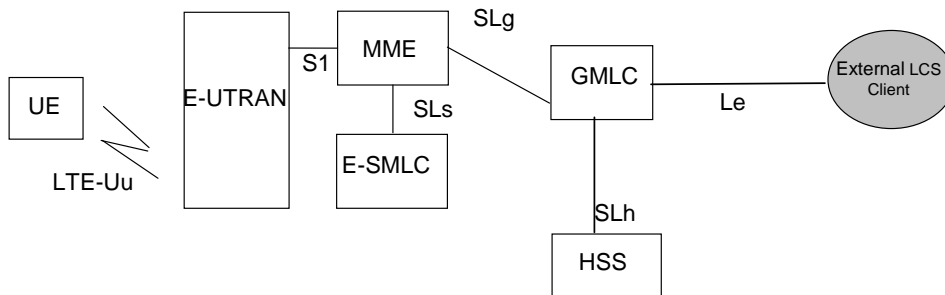

Figure 3a: Configuration of LCS entities for an E-UTRAN PLMN

### 5.3 Configuration of CAMEL entities

The following figure shows the interconnection of the CAMEL-specific entities with the rest of the network. Only the interfaces specifically involved in CAMEL provisioning are shown, i.e. all the GMSC, MSC, SGSN and HLR interfaces depicted in figure 1 are still supported by these entities even if not shown. CAMEL is not supported for E-UTRAN access.

NOTE: Most CAMEL-specific interfaces have no particular name. They are designated by the name of the two entities they link together, e.g. "the gsmSSF-gsmSCF interface".

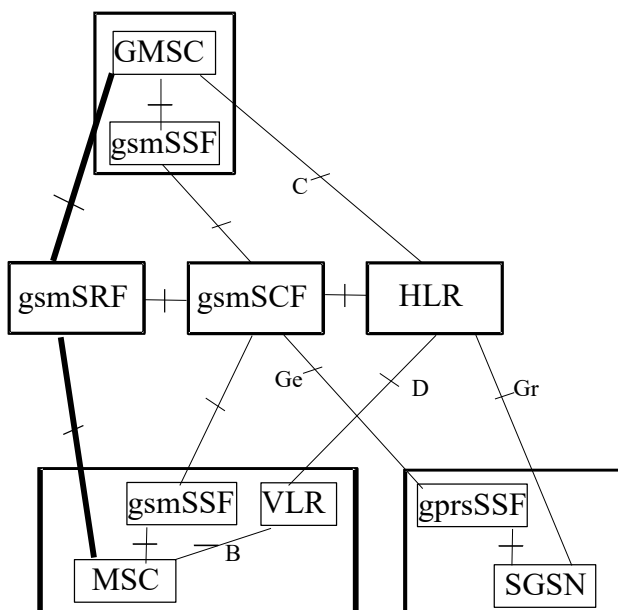

Figure 4: configuration of CAMEL entities

The bold lines are used for interfaces supporting user data only, the dashed lines are used for interfaces supporting signalling only.

## 5.4 Configuration of CBS entities

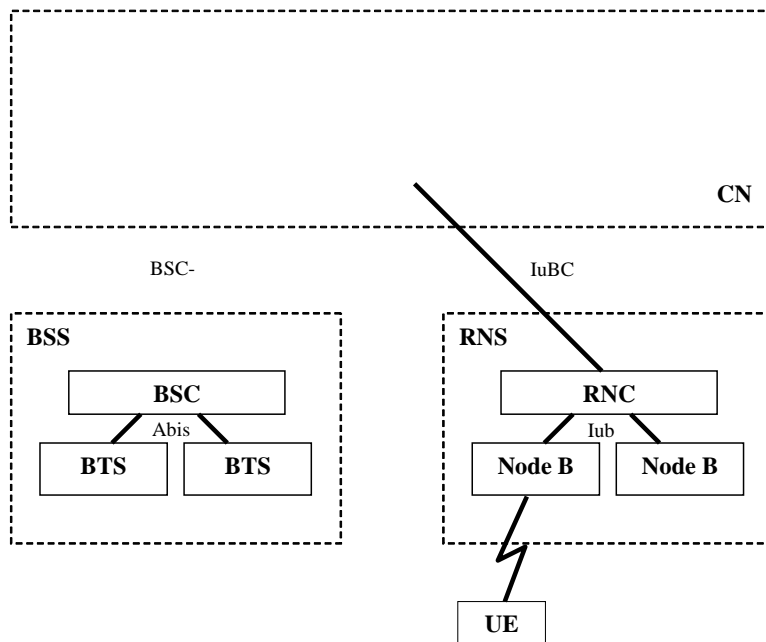

Figure 5: Configuration of a PLMN supporting Cell Broadcast Service entities for GERAN/UTRAN

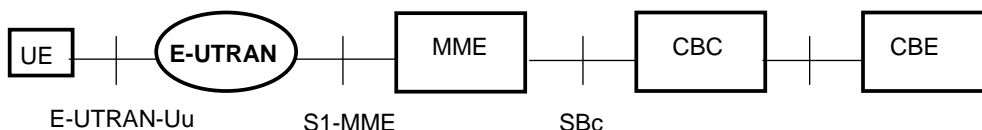

Figure 4.2.3-1: Warning System Architecture for E-UTRAN Access

NOTE: The CBE and the interface between CBE and CBC are out of scope of 3GPP specifications.

## 5.5 Configuration of IM CN Subsystem entities

### 5.5.1 IM CN Subsystem functional entities

The configuration of IM CN Subsystem entities is presented in figure 6. In the figure, all the functions are considered implemented in different logical nodes. If two logical nodes are implemented in the same physical equipment, the relevant interfaces may become internal to that equipment.

Only the interfaces specifically linked to the IM CN subsystem are shown, i.e. all the SGSN, GGSN, S-GW, PDN-GW and HSS interfaces depicted in figure 1 and figure 1b are still supported by these entities even if not shown.

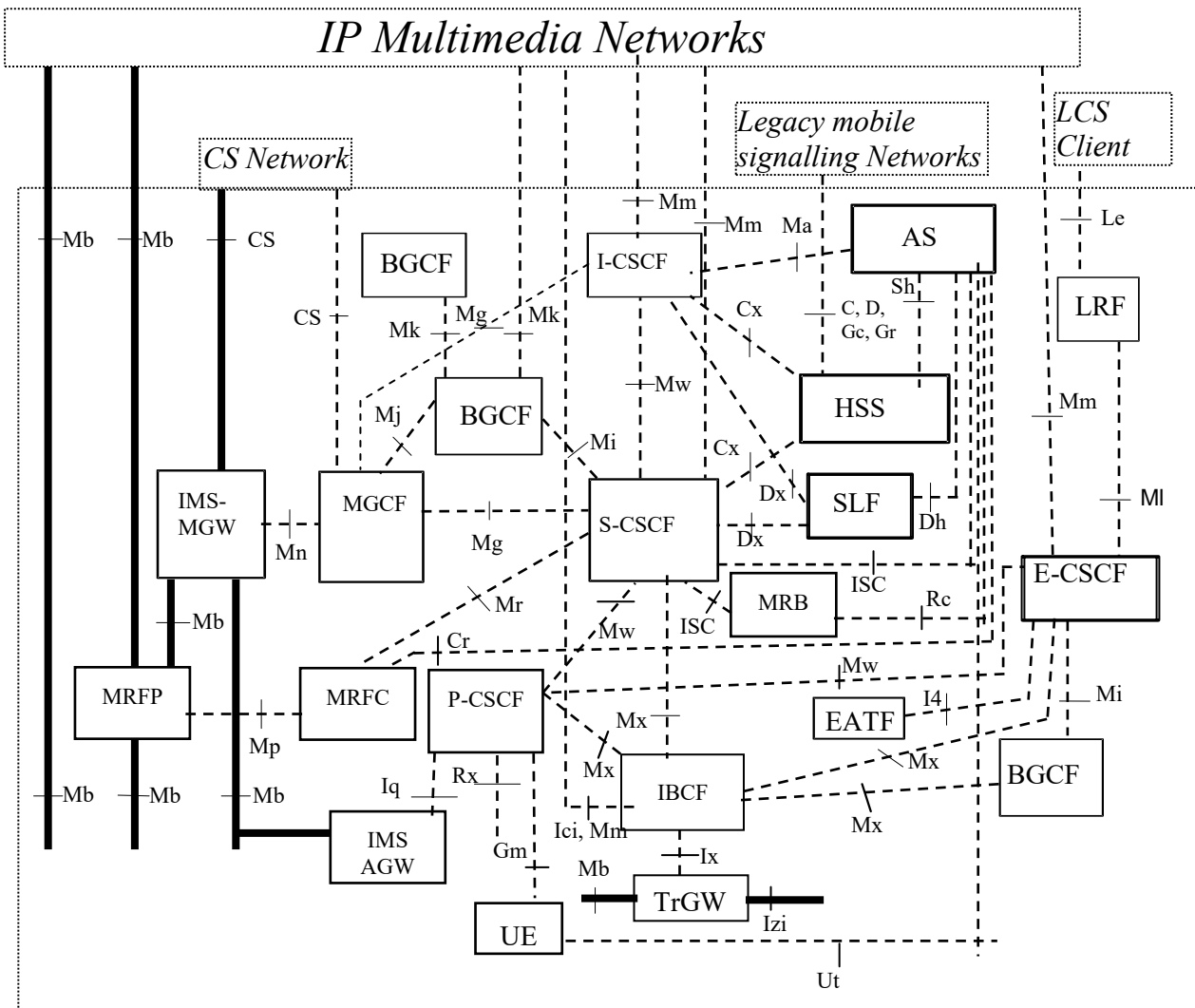

Legend:  
 Bold lines: interfaces supporting user traffic;  
 Dashed lines: interfaces supporting only signalling.

NOTE 1: The reference point CS (Circuit Switched) is not specified in this specification.  
 NOTE 2: The reference point I5 is not shown in this figure.

**Figure 6: Configuration of IM Subsystem entities**

### 5.5.2 IM CN Subsystem Service layer

The figure below depicts an overall view of the functional architecture for services.

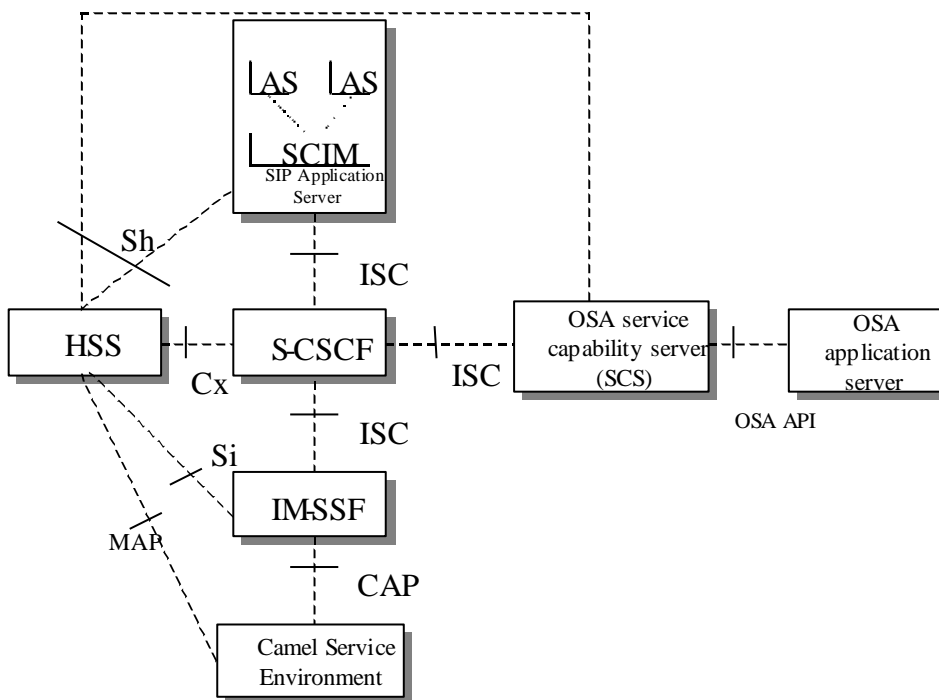

**Figure 6a: Functional architecture for the provision of service in the IMS**

The purpose of the IM SSF is to host the CAMEL network features (i.e. trigger detection points, CAMEL Service Switching Finite State Machine, etc.) and to interwork with CAP. The IMS-SSF may receive CAMEL subscription data from HSS via Sh reference point in addition to the Si reference point.

The IM SSF and the CAP interface support legacy services only.

The application server may contain "service capability interaction manager" (SCIM) functionality and other application servers. The SCIM functionality is an application which performs the role of interaction management. The internal components are represented by the "dotted boxes" inside the SIP application server. The internal structure of the application server is outside the standards. The Sh interface shall have sufficient functionality to enable this scenario.

The figure below depicts an overall view of the functional architecture for enabling the management of the user's service related information via the Ut interface.

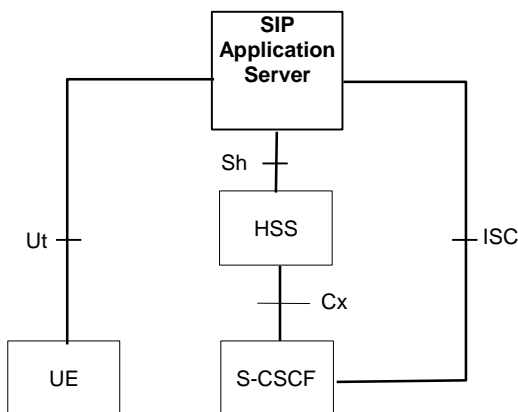

**Figure 6b: Functional architecture for the management of the user's service related information**

The figure below depicts an overall view of the functional architecture for routing SIP requests between I-CSCF and Application Server.

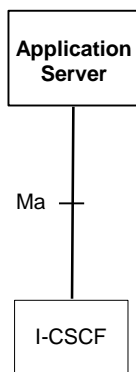

**Figure 6c: Functional architecture for the routing of SIP requests between I-CSCF and AS**

### 5.5.3 Service Centralization and Continuity

Figure 6d depicts an overall view of the functional architecture for IMS services centralization and continuity.

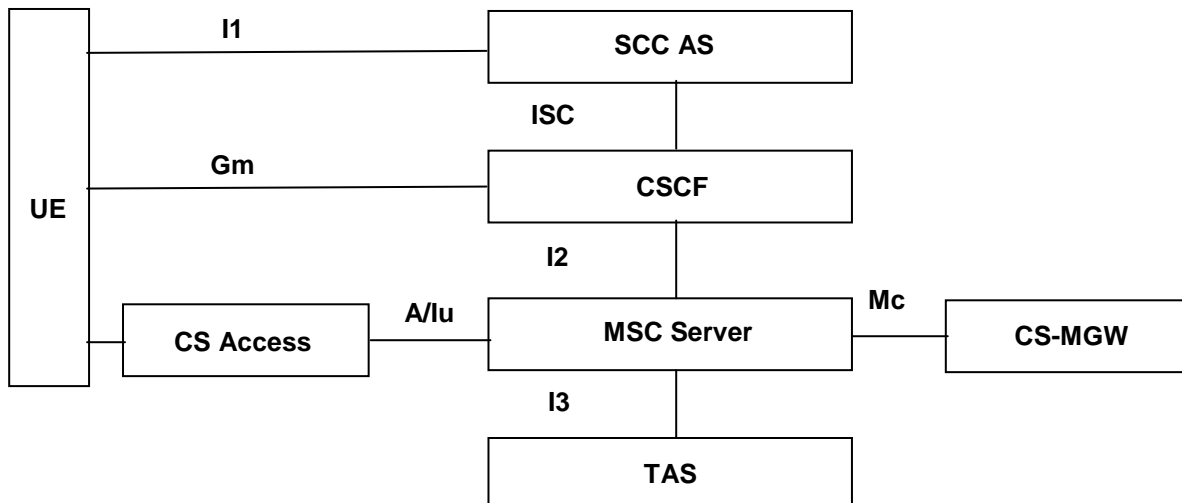
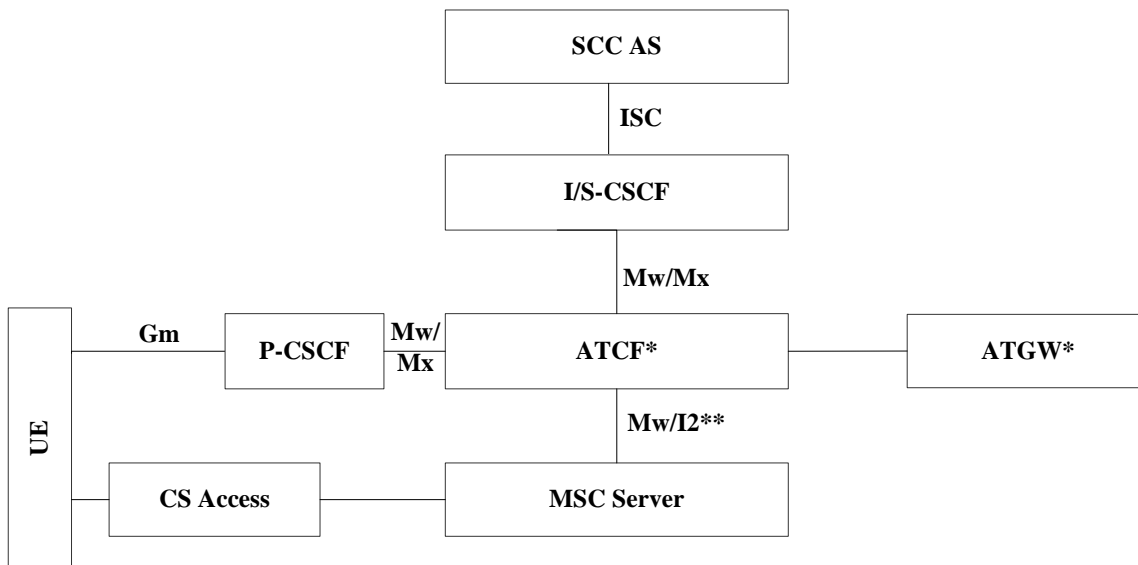

**Figure 6d: Functional architecture for IMS Service Centralization and Continuity**

IMS Service Centralization, defined in TS 23.292 [110] provides communication services such that all services, and service control, are based on IMS mechanisms and enablers. It enables IMS services when using CS access as bearer for the media.

IMS Service Continuity, defined in TS 23.237 [111] provides Session Transfer mechanisms to maintain service continuity in the event of access transfer for the case when such events are not hidden from the IMS session layer and thus service continuity could not otherwise be maintained.

Figure 6e provides the reference architecture for SRVCC using the ATCF enhancements as defined in TS 23.237 [111]. The ATCF enhancements provide Session Transfer mechanisms in the serving network to maintain service continuity in the event of access transfer for SRVCC.



\*: Location of functionality depends on deployment and collocation scenario

\*\* : Reference point dependent on MSC Server capability.

**Figure 6e: IMS Service Centralization and Continuity Reference Architecture when using ATCF enhancements**

If neither the MSC Server is not enhanced for ICS, the interface between MSC Server and ATCF is Mw.

NOTE 2: If the MSC Server is enhanced for ICS, the interface between MSC Server and ATCF is I2.

### 5.5.4 WebRTC access to IMS

Figure 5.5.4-1 depicts an overall view of the functional architecture for WebRTC access to IMS.

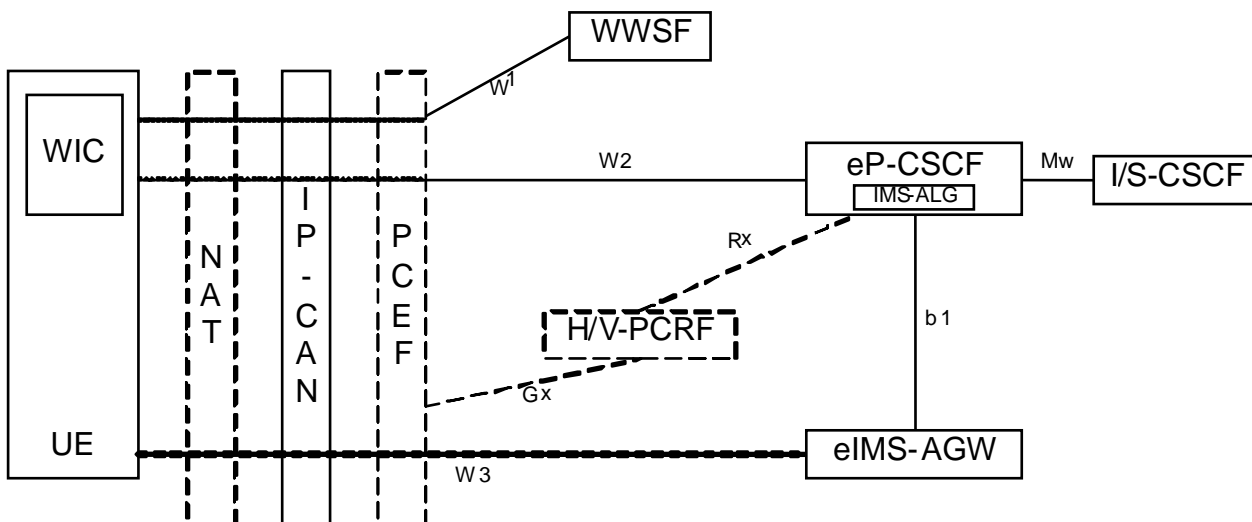

NOTE: The presence of dashed elements in the figure depends on the configuration. PCC functional elements are present only for EPC access with QoS. The corresponding PCC elements for fixed access are also optionally supported but not shown. The NAT is meant for non-cellular access to IMS.

**Figure 5.5.4-1: Functional architecture for WebRTC access to IMS**

The architecture and the procedures to provide communication services to WebRTC IMS clients (WIC) are defined in Annex U of TS 23.228 [34].

## 5.6 Configuration of Signalling Gateway Function

The Signalling gateway function is used to interconnect different signalling networks i.e. SCTP/IP based signalling networks and SS7 signalling networks. The application layer (e.g. ISUP, BICC, MAP or CAP) is not affected. The signalling gateway function may be implemented as a stand alone entity or inside another entity.

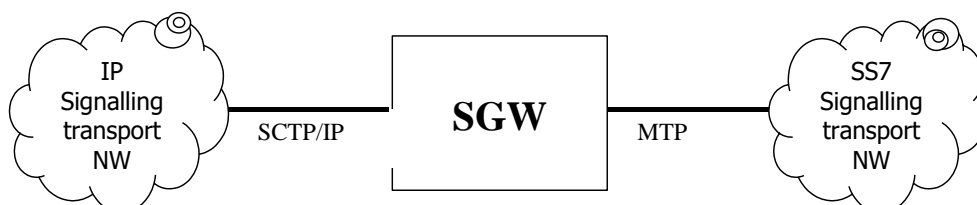

**Figure 7: Configuration of a signalling gateway function**

NOTE: SS7 application transport and SCTP/IP adaption protocols are not shown.

## 5.7 Configuration of 3GPP/WLAN Interworking

The configuration of the 3GPP/WLAN interworking function is presented in figure 8. The figure shows all network entities and reference point for the roaming scenario when a WLAN UE accesses PS based services in the home network. PS based services in the visited network are accessed via a Packet Data Gateway in the visited 3GPP network. Reference point Ww between WLAN UE and WLAN is outside the scope of 3GPP and only shown for completeness.

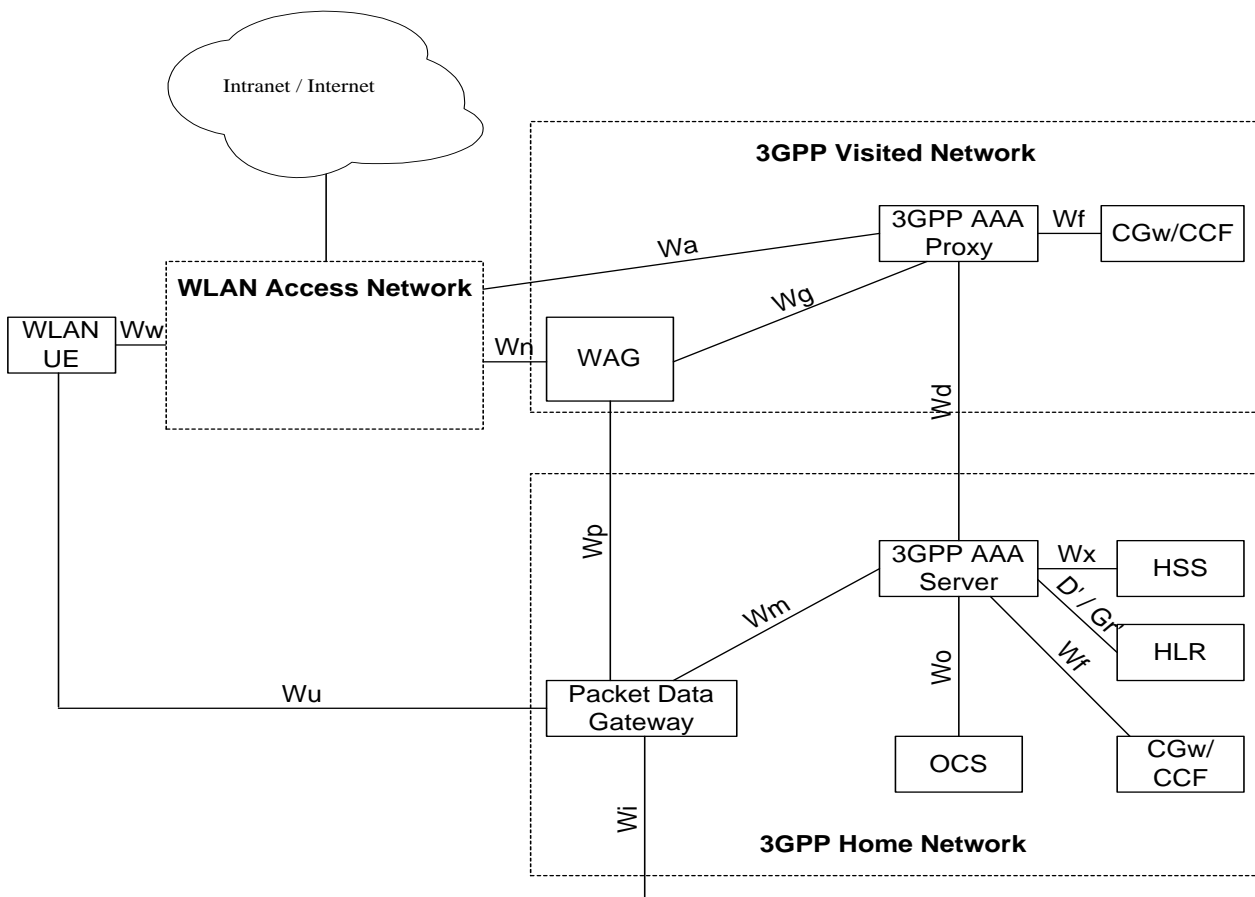

Figure 8: Configuration of a 3GPP/WLAN interworking function

## 5.8 Configuration of Presence service

The reference architecture model, the reference points and the functional entities to support the Presence Service are described in TS 23.141 [68].

## 5.9 Configuration of MBMS entities

The configuration of the MBMS entities for GPRS and EPS is represented in figures 9 and 9a respectively. MBMS for GPRS supports UTRAN and GERAN. MBMS for EPS supports E-UTRAN and UTRAN.

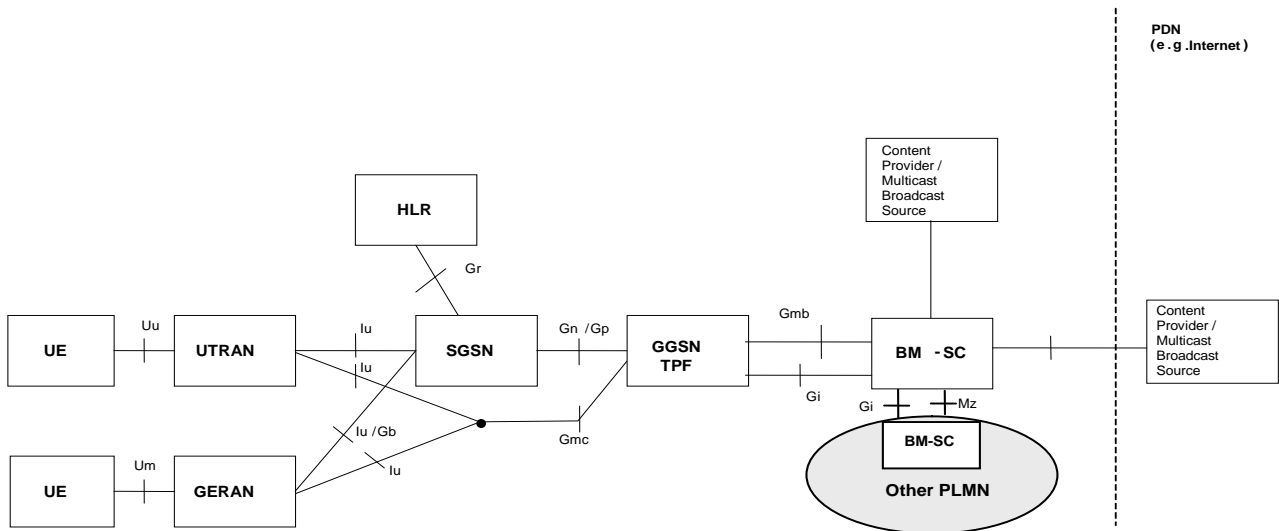
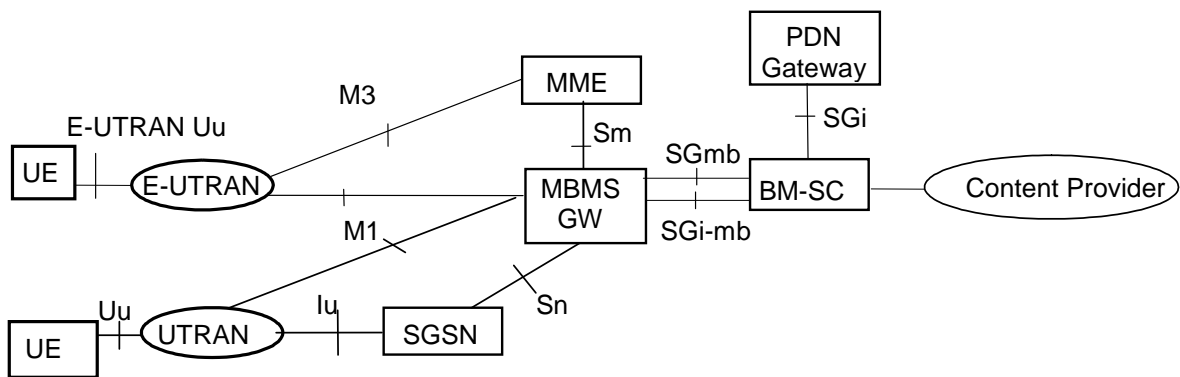

Figure 9: Configuration of MBMS entities for GPRS



NOTE: The MCE (Multi-cell/Multicast Coordination Entity) is not shown in the figure. See TS 36.300 [78].

Figure 9a: Configuration of MBMS entities for Evolved Packet System

## 5.10 Configuration of Short Message Service over generic 3GPP Internet Protocol access (SMSIP) entities

The configuration of the Short Message Service over generic 3GPP Internet Protocol access (SMSIP) entities are represented in figure 10.

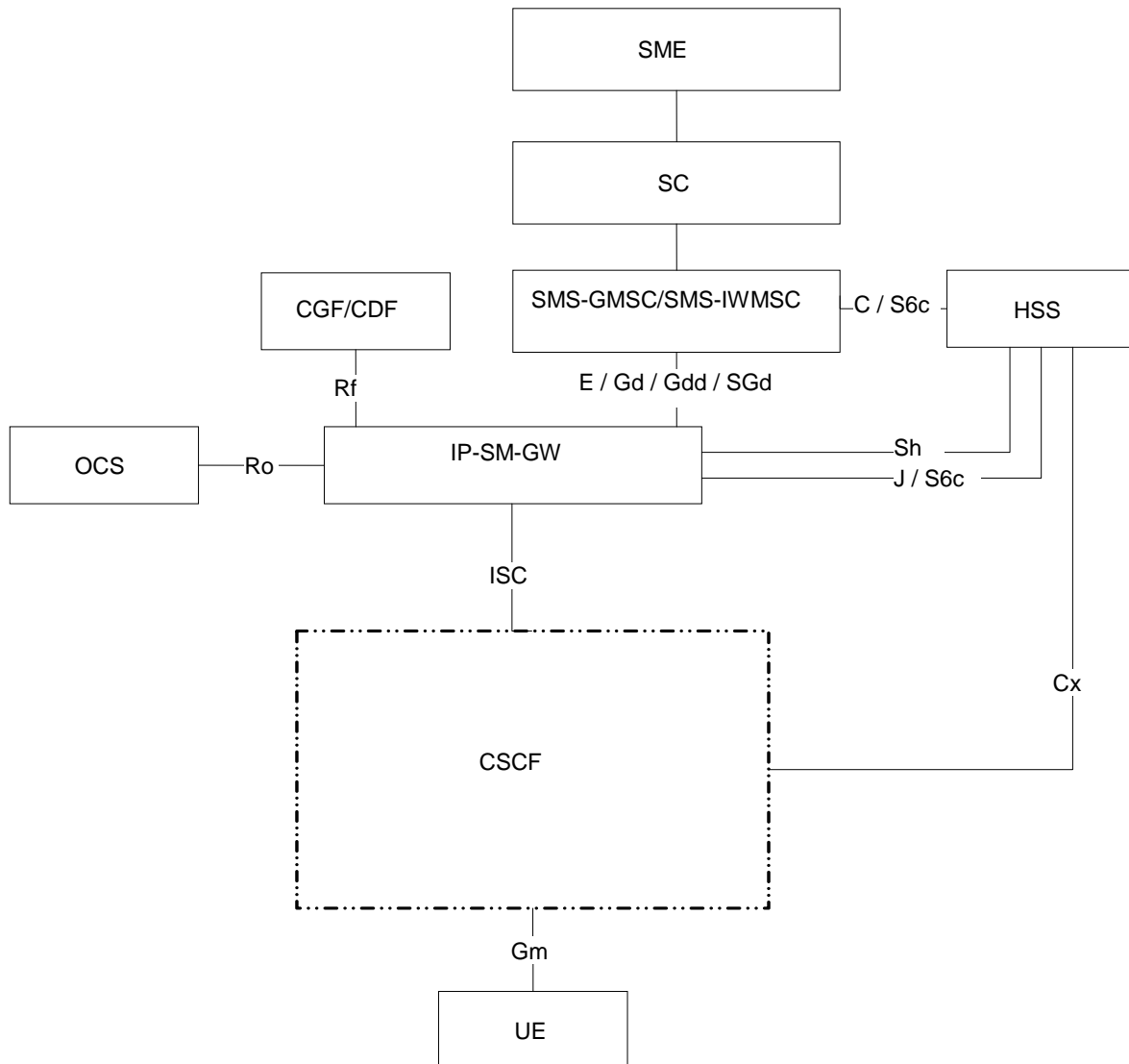

**Figure 10: Configuration of SMSIP entities**

## 5.11 Configuration of Policy Control and Charging entities

The PCC functionality is comprised by the functions of the Policy and Charging Enforcement Function (PCEF), the Bearer Binding and Event Reporting Function (BBERF), the Policy and Charging Rules Function (PCRF), the Application Function (AF), the Online Charging System (OCS), the Offline Charging System (OFCS), the Traffic Detection Function (TDF), the Traffic Steering Support Function (TSSF) and the Subscription Profile Repository (SPR) or the User Data Repository (UDR). Figures 5.11-1 through to 5.11-4 describe the non-roaming and roaming architecture for PCC.

The PCRF can receive RAN User Plane Congestion Information from the RAN Congestion Awareness Function (RCAF).

The PCC architecture extends the architecture of an IP-CAN, where the Policy and Charging Enforcement Function is a functional entity in the Gateway node implementing the IP access to the PDN. The allocation of the Bearer Binding and Event Reporting Function is specific to each IP-CAN type and specified in the TS 23.203 [73].

PCC function makes it possible to apply policy and charging control to any kind of 3GPP IP CAN and any non-3GPP accesses connected via EPC complying with TS 23.402 [77]. Applicability of PCC to other IP CAN is not restricted; however, it shall be possible for the PCC architecture to base decisions upon the type of IP CAN used (e.g. GPRS, I-WLAN, etc.). Support for policy control and charging when local breakout and roaming are applied as specified in TS 23.401 [76] and TS 23.402 [77] is supported.

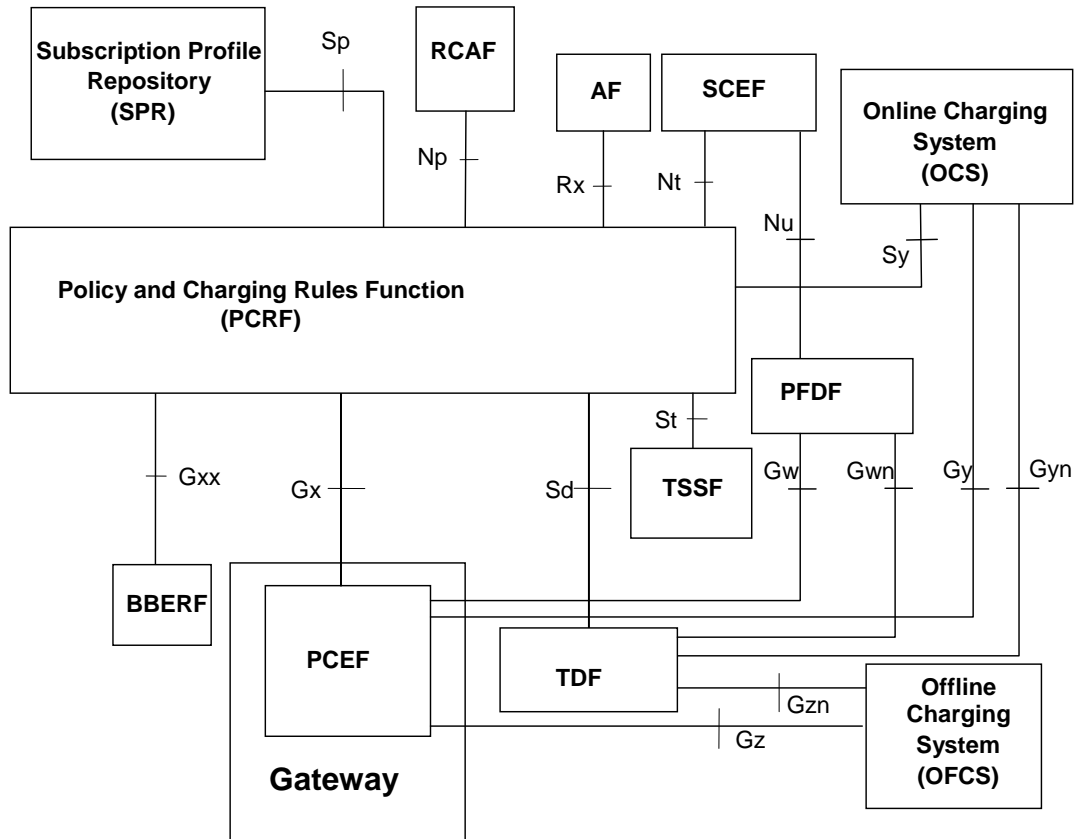

Figure 5.11-1: Overall PCC logical architecture (non-roaming) when SPR is used

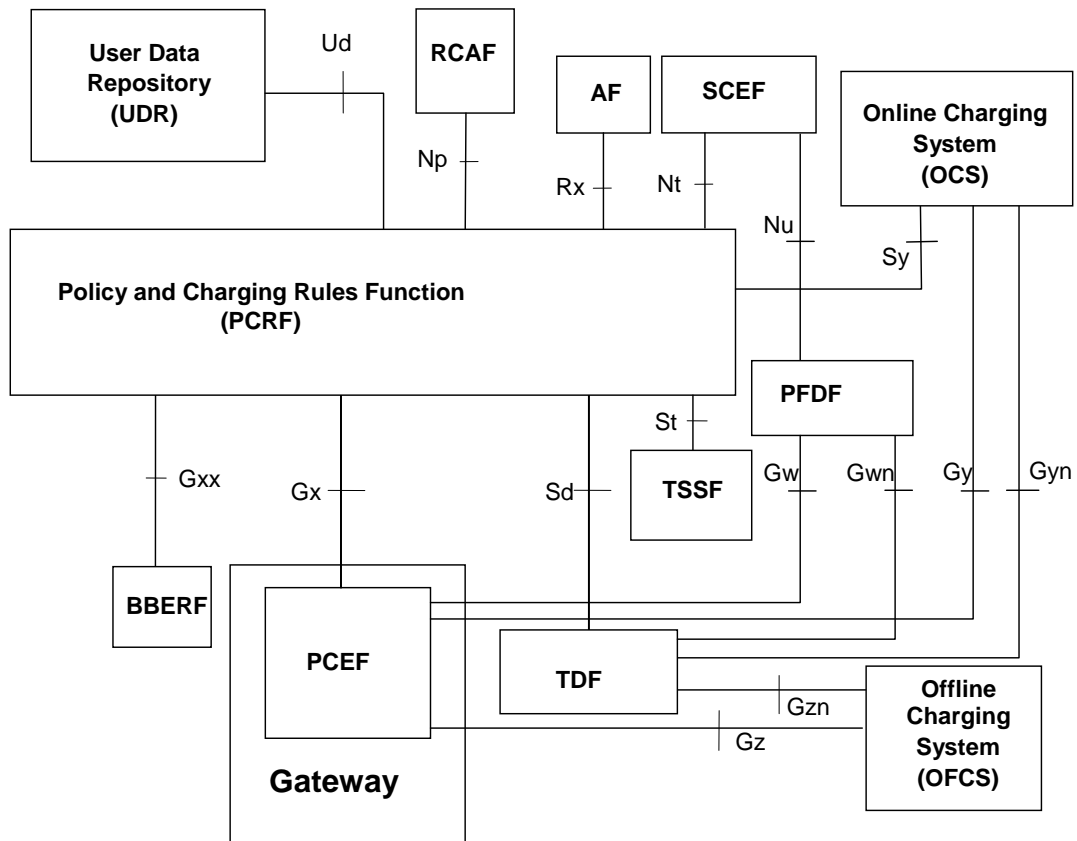

Figure 5.11-2: Overall PCC logical architecture (non-roaming) when UDR is used

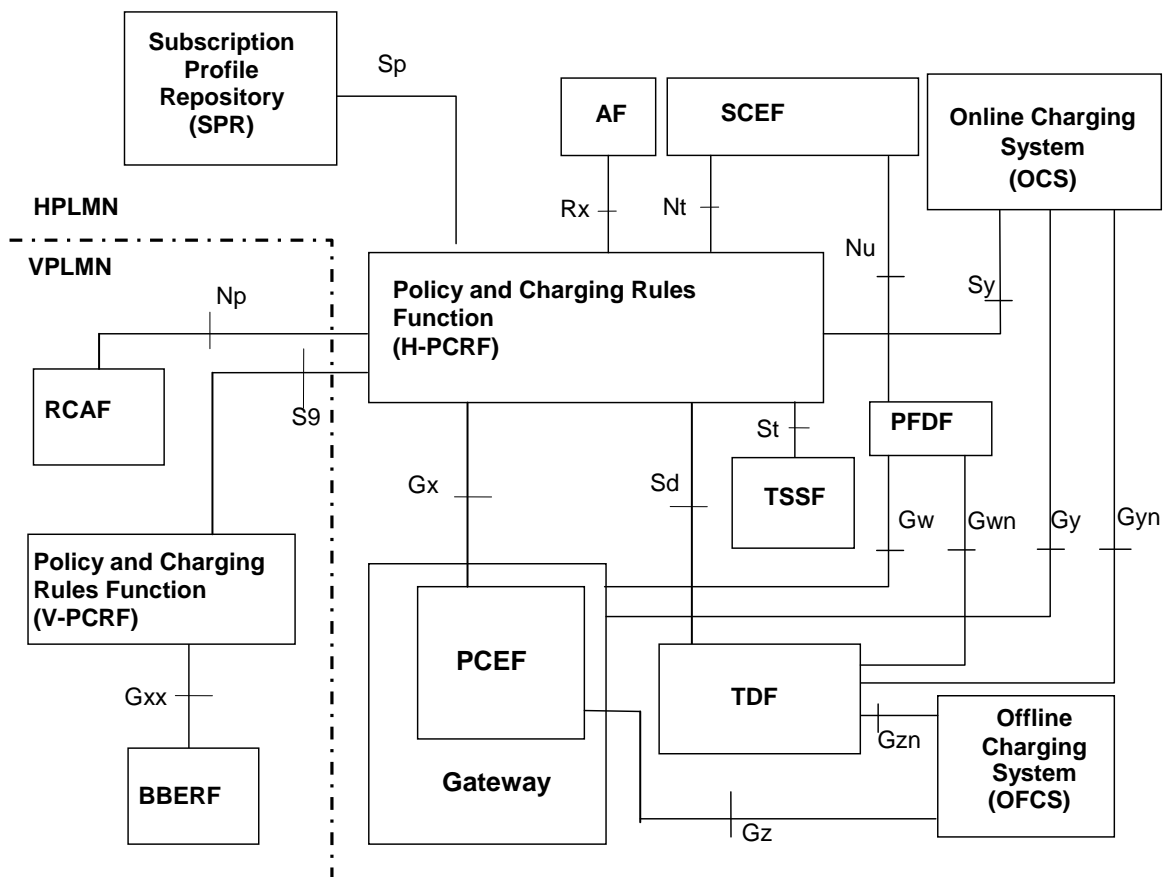
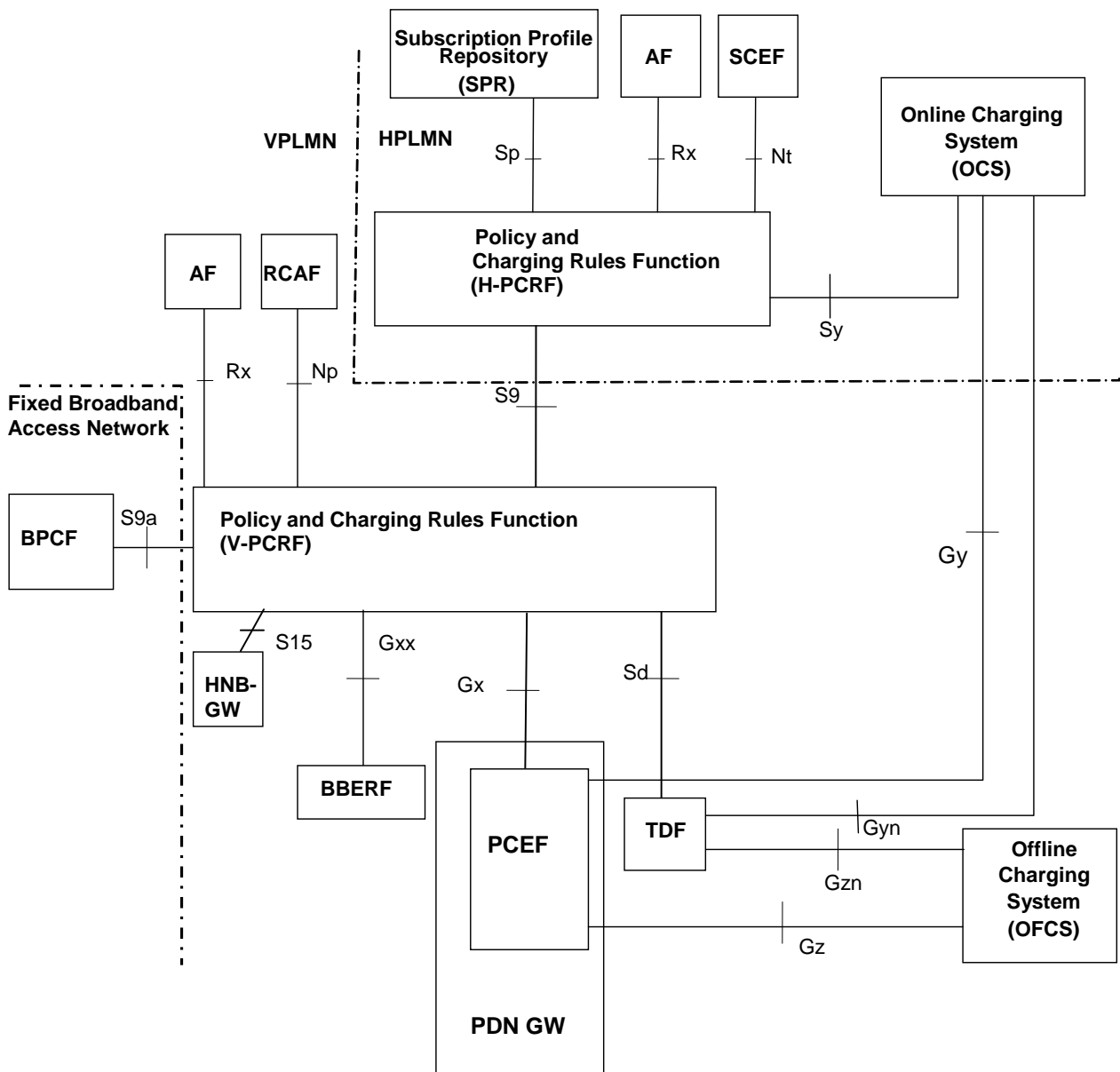

Figure 5.11-3: Overall PCC architecture (roaming with home routed access) when SPR is used



**Figure 5.11-4: Overall PCC architecture for roaming with PCEF in visited network (local breakout) when SPR is used**

NOTE 1: The SCEF acts as an AF (using Rx) in some service capability exposure use cases as described in TS 23.682 [132].

NOTE 2: The PCEF of PDN GW and the TDF can be further split into control plane entities (PGW-C and TDF-C) and user plane entities (PGW-U and TDF-U). The architecture reference model for the control plane and user plane separation is defined in TS 23.214 [145].

## 5.12 Configuration of CSFB(CS Fallback)

The CS fallback in EPS enables the provisioning of voice and other CS-domain services (e.g. CS UDI video/ SMS/ LCS/ USSD) by reuse of CS infrastructure when the UE is served by E-UTRAN. This function is only available in case E-UTRAN coverage is overlapped by either GERAN coverage or UTRAN coverage.

The configurations of the CSFB entities are represented in figure 5.12.

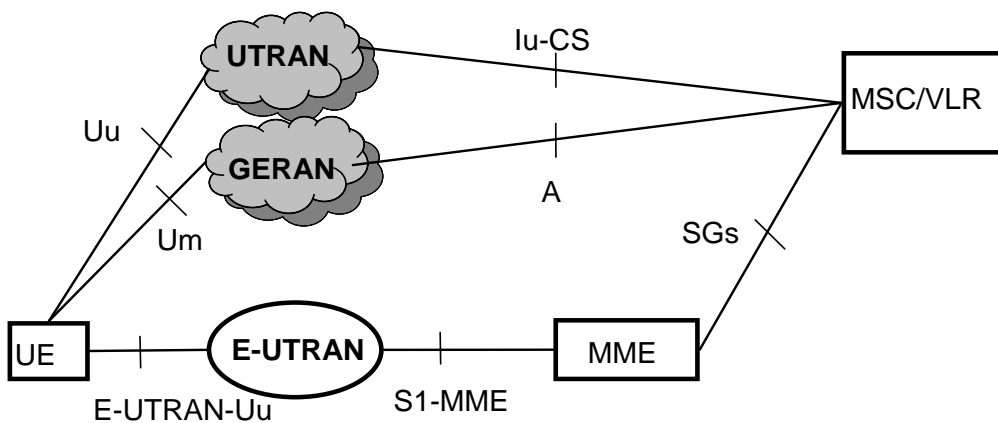

Figure 5.12: Configuration of CSFB

NOTE: The MGW is not shown in the figure 5.12 since the CS fallback in EPS does not have any impacts to the User plane handling.

## 5.13 Configuration of Single Radio Voice Call Continuity (SRVCC)

### 5.13.1 E-UTRAN/UTRAN (HSPA) to UTRAN or GERAN SRVCC architecture

Single Radio Voice Call Continuity (PS to CS) refers to continuity between IMS over PS access and CS calls that are anchored in IMS when the UE is capable of transmitting/receiving on only one of those access networks at a given time. PS to CS SRVCC is specified in TS 23.216 [83]. The following figures 5.13, 5.13a and 5.13b show the entities involved in PS to CS SRVCC.



Figure 5.13: SRVCC architecture for E-UTRAN to 3GPP UTRAN/GERAN

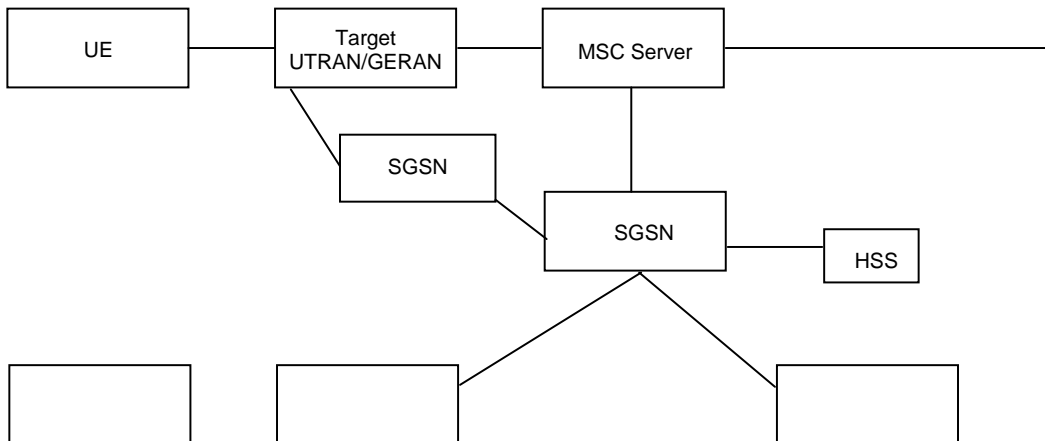

Figure 5.13a: SRVCC architecture for UTRAN (HSPA) to 3GPP UTRAN/GERAN with Gn based SGSN

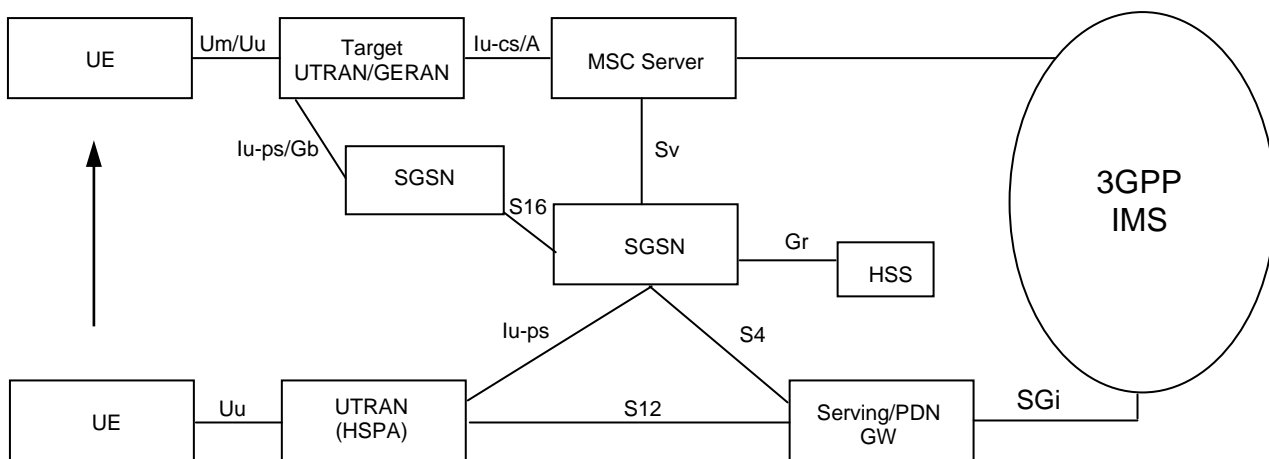
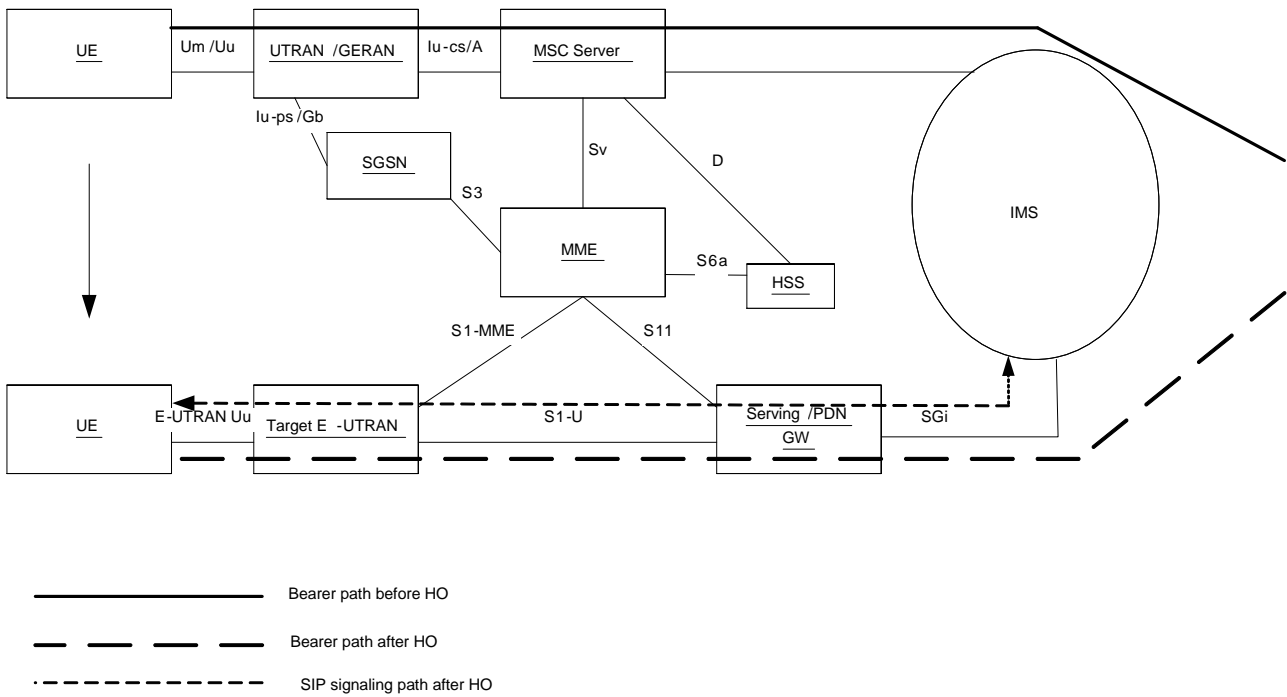

Figure 5.13b: PS to CS SRVCC architecture for UTRAN (HSPA) to 3GPP UTRAN/GERAN with S4 based SGSN

- NOTE 1: The above figures only show the necessary components related to MSC Server enhanced with SRVCC.
- NOTE 2: MSC Server shown in the above figures are enhanced for SRVCC.
- NOTE 3: This architecture also applies to roaming scenario (i.e., S8, S6a are not impacted due to SRVCC).
- NOTE 4: The MSC Server enhanced with SRVCC may not be the final target MSC which connects to the target cell.

### 5.13.2 UTRAN/GERAN to E-UTRAN or UTRAN (HSPA) SRVCC architecture

CS to PS Single Radio Voice Call Continuity refers to continuity between a CS call and IMS call over PS access that are anchored in IMS when the UE is capable of transmitting/receiving on only one of those access networks at a given time. CS to PS SRVCC is specified in TS 23.216 [83]. The following figures 5.13c, 5.13d and 5.13e show the entities involved in CS to PS SRVCC.



- NOTE 1: The above figure only shows the necessary components related to MSC Server enhanced for CS to PS SRVCC.
- NOTE 2: MSC Server shown in the figure is enhanced for CS to PS SRVCC.
- NOTE 3: This architecture also applies to roaming scenario (i.e. S8, S6a are not impacted due to CS to PS SRVCC).

**Figure 5.13c: CS to PS SRVCC architecture for UTRAN/GERAN to E-UTRAN**

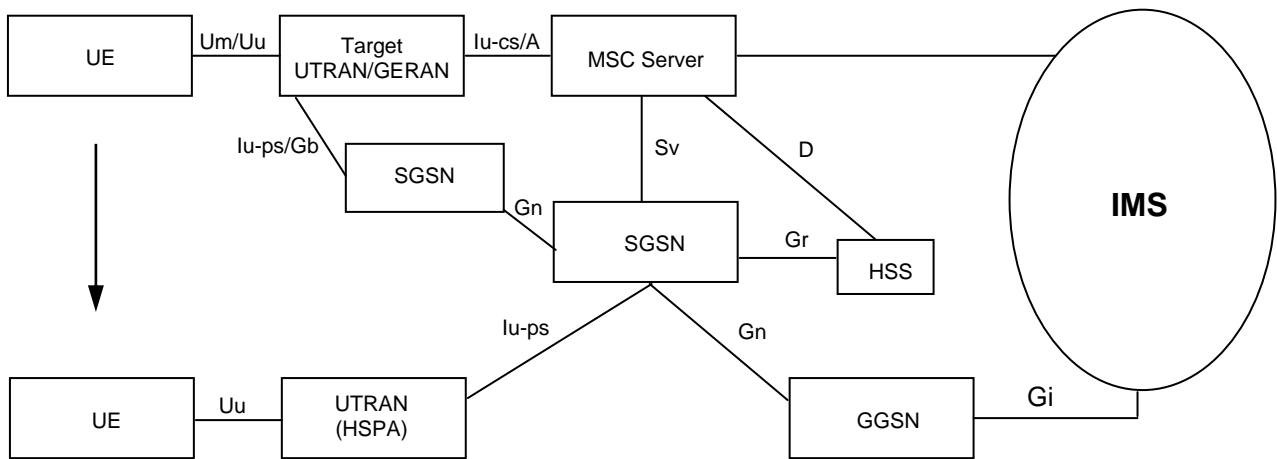

**Figure 5.13d: CS to PS SRVCC architecture for UTRAN/GERAN to UTRAN (HSPA) with Gn based SGSN**

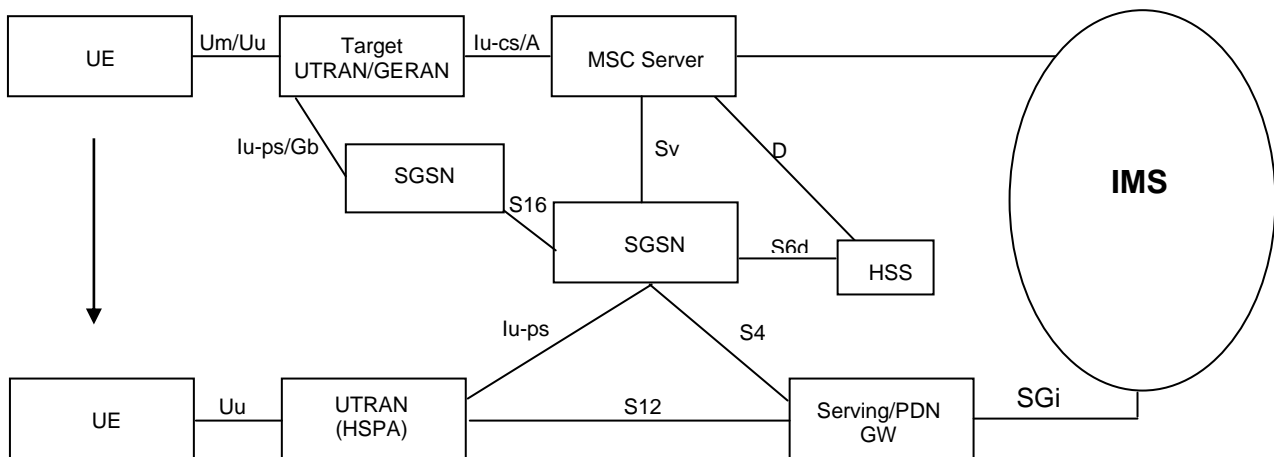

NOTE 1: The above figures only show the necessary components related to MSC Server enhanced with CS to PS SRVCC.

NOTE 2: MSC Server shown in the above figures are enhanced for CS to PS SRVCC.

NOTE 3: This architecture also applies to roaming scenario.

**Figure 5.13e: CS to PS SRVCC architecture for UTRAN/GERAN to UTRAN (HSPA) with S4 based SGSN**

## 5.14 Configuration of Security

The reference architecture model, the reference points and the functional entities to support and provide security related functions to the users, devices and network entities when in the UTRAN access as well as using IMS are described in TS 33.1xx series and TS 33.2xx series.

The reference architecture model, the reference points and the functional entities to support security functions to the users, devices and network entities when in the EPC are described in TS 33.401 [87] for 3GPP access and in TS 33.402 [88] for non-3GPP accesses.

## 5.15 Configuration of Lawful Intercept related entities

The general configuration for Lawful Interception is shown in figure 5.15. The definition of the LI functional entities and interfaces is provided in TS 33.107 [84].

The reference configuration is only a logical representation of the entities involved in lawful interception and does not mandate separate physical entities. There is one Administration Function (ADMF) in the network. Every physical Intercepting Control Element (ICE) is linked by its own X1\_1-interface to the ADMF. Consequently, every single ICE performs interception (activation, deactivation, interrogation as well as invocation) independently from other ICEs.

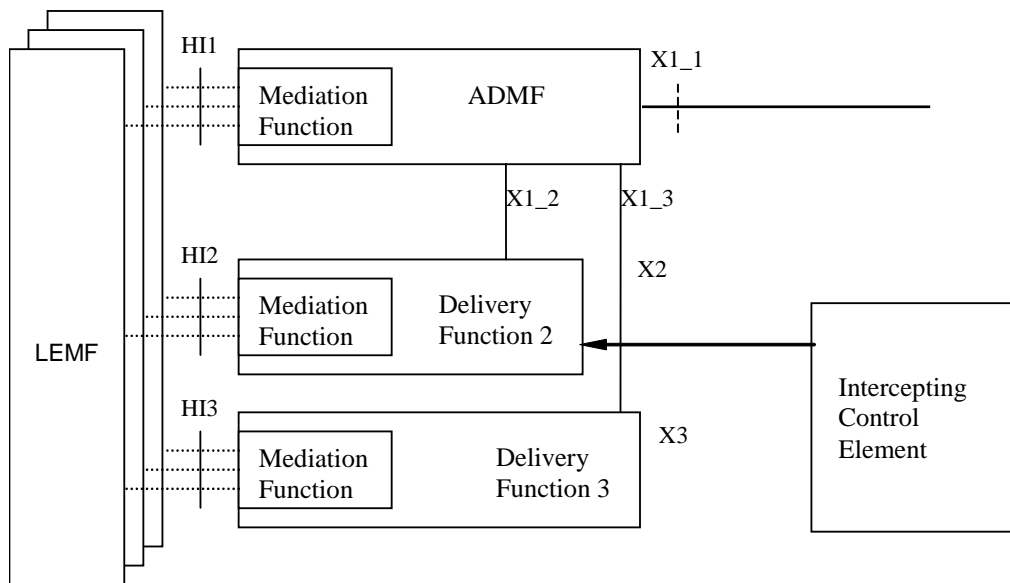

**Figure 5.15: General Lawful Interception Architecture**

## 5.16 Configuration of Charging related entities

The general configuration for common charging architecture for 3GPP defined entities is shown in figure 5.16 as defined in TS 32.240 [85]. This common charging architecture provides a logical view and the actual domain / service / subsystem specific charging architecture depends on the domain / service / subsystem in question. The physical mapping of the common logical architecture onto each domain, subsystem or service is described in the respective charging specifications, i.e. the TSs 32.25x, 32.26x and 32.27x number range.

3GPP networks provide functions that implement offline and/or online charging mechanisms on the bearer (e.g. EPC), subsystem (e.g. IMS) and service (e.g. MMS) levels. In order to support these charging mechanisms, the network performs real-time monitoring of resource usage on the above three levels in order to detect the relevant chargeable events.

In offline charging, the resource usage is reported from the network to the Billing Domain after the resource usage has occurred. In online charging, a subscriber account, located in an Online Charging System, is queried prior to granting permission to use the requested network resource(s).

Offline and online charging may be performed simultaneously and independently for the same chargeable event.



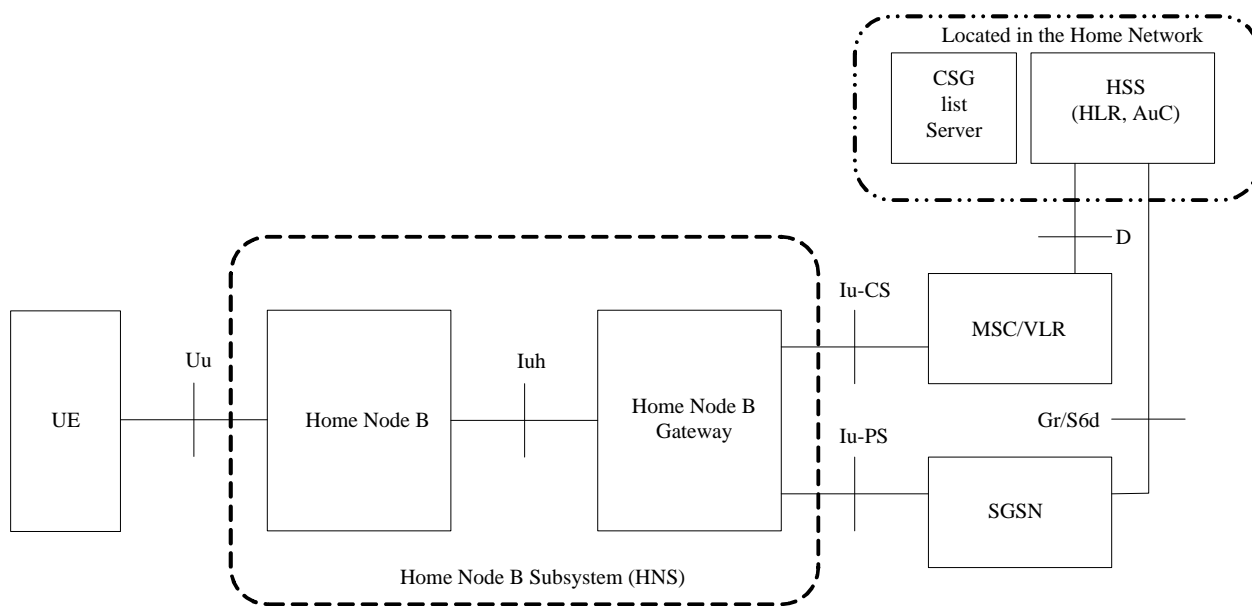

**Figure 5.17-1: Configuration of PLMN supporting Home NodeB Subsystem**

### 5.17.2 Configuration of the Home eNodeB Subsystem

The configuration of Home eNodeB Subsystem with a Home eNodeB Gateway present is shown in figure 5.17-2. In the figure, all the functions are considered implemented in different logical nodes. If two logical nodes are implemented in the same physical equipment, the relevant interfaces may become internal to that equipment.

The presence of Home eNodeB Gateway in the configuration of Home eNodeB Subsystem is optional.

The Home eNodeB Gateway may also be used only for the S1-MME interface. In this case, the S1-U interface is directly between the Home eNodeB and the S-GW.

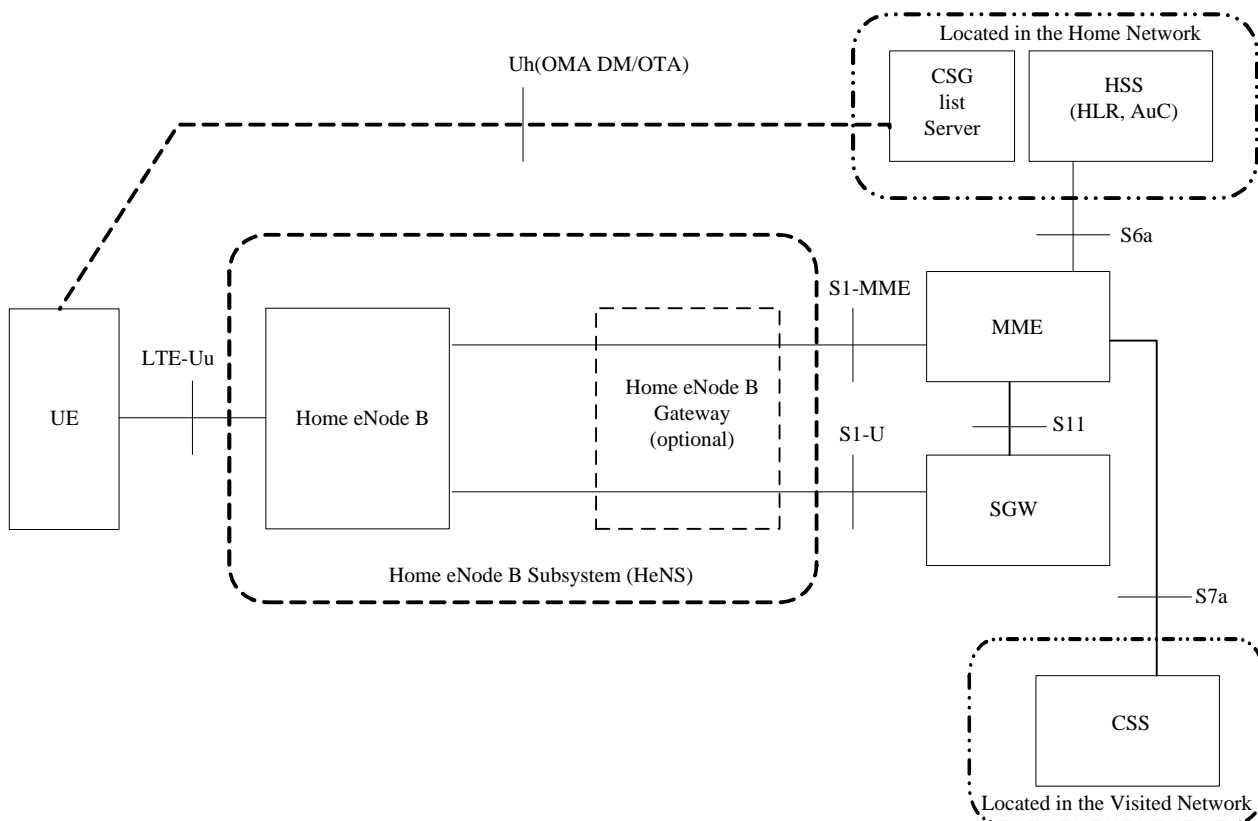

Figure 5.17-2: Configuration of PLMN supporting Home eNodeB Subsystem

## 5.18 Configuration for facilitating communications with packet data networks and applications

The reference architecture model, the reference points and the functional entities to facilitate communications with packet data networks and applications are described in TS 23.682 [132].

## 5.19 Configuration of Packet Switched Streaming (PSS) Service

The configuration of the PSS entities for GPRS and EPS is represented in figures 5.19-1 and 5.19-2 respectively. PSS for GPRS supports UTRAN and GERAN. PSS for EPS supports E-UTRAN, UTRAN and GERAN. Further details of the PSS Service are described in TS 26.233 [139].

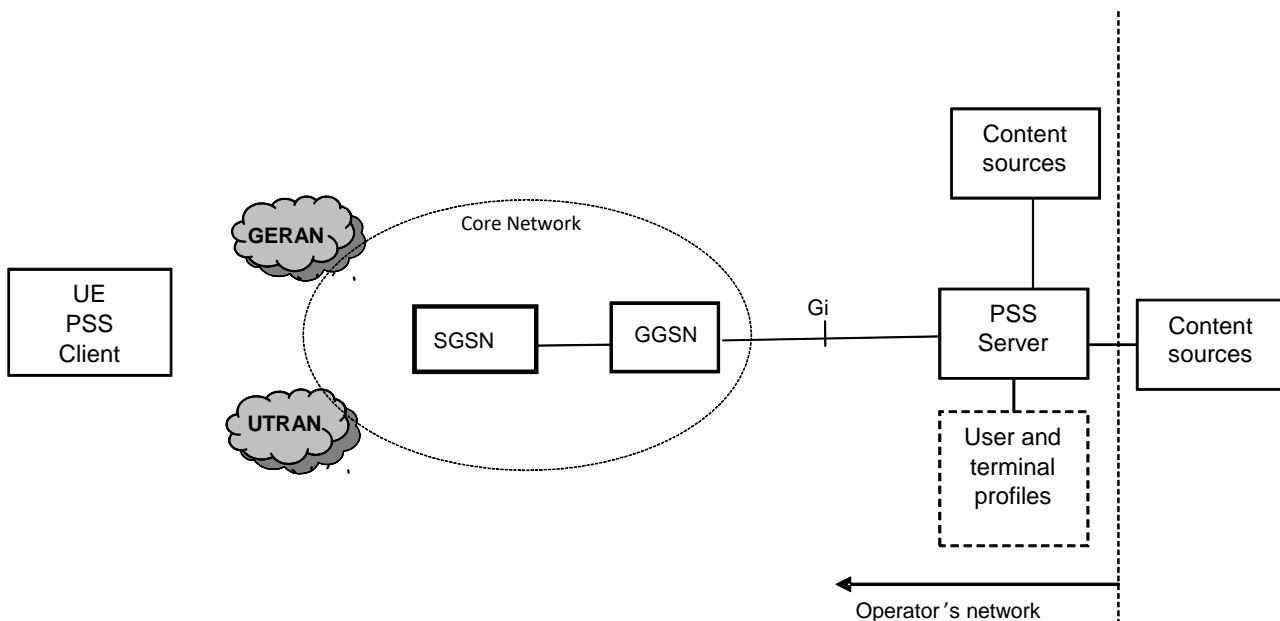

Figure 5.19-1: PSS Service Architecture for GPRS



Rx



Figure 5.19-2: PSS Service Architecture for EPS

## 5.20 Configuration of Proximity-based Services

The reference architecture model, the reference points and the functional entities to facilitate ProSe are described in TS 23.303 [141].

## 5.21 Configuration for RAN user plane congestion detection and reporting

RAN user plane congestion detection and reporting enables the PCRF to take the RAN user plane congestion status into account for policy decisions. This functionality is applicable only in case of UTRAN/E-UTRAN accesses. The configuration of the related entities is depicted in Figure 5.21.

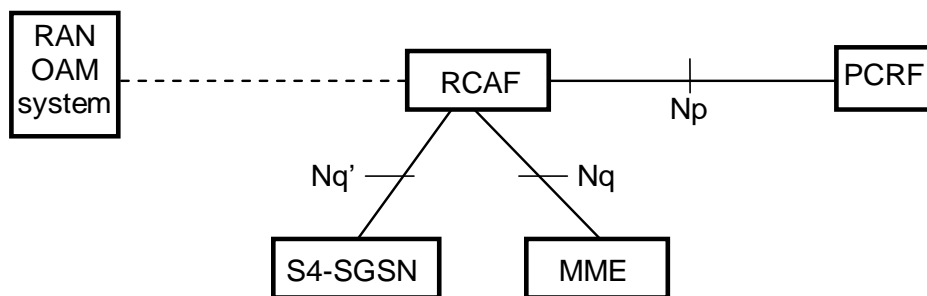

**Figure 5.21: Configuration for RAN user plane congestion detection and reporting**

NOTE: The interface to the RAN's OAM system is not standardized.

## 6 PLMN basic interfaces and reference points

The implementation of the mobile service with international roaming implies the exchange of data between the equipment involved in the service. The same No.7 signalling network should be used to transfer these data and the call-related signalling information.

*Editor's note: either the difference between interface and reference point should be clearly provided, or only one of the terms should be used.*

### 6.1 Interfaces between Mobile Station and the Fixed Infrastructure

#### 6.1.1 Interface between Mobile Station and Base Station System (Um-interface)

The interface between the MS and the BSS is specified in the 44- and 45-series of Technical Specifications.

#### 6.1.2 Interface between User Equipment and Radio Network System (Uu-interface)

The interface between the UE and the RNS is specified in the 24- and 25-series of Technical Specifications.

#### 6.1.3 Interface between User Equipment and Evolved UTRAN (E-UTRAN Uu-interface)

The interface between the UE and the E-UTRAN is specified in the 36-series of Technical Specifications.

### 6.2 Interface between the Core Network and the Access Network

#### 6.2.1 Interfaces between the CS domain and the Access Network

##### 6.2.1.1 Interface between the MSC and Base Station System (A-interface)

The interface between the MSC and its BSS is specified in the 48-series of Technical Specifications.

The BSS-MSC interface is used to carry information concerning:

- BSS management;
- call handling;
- mobility management.

### 6.2.1.2 Interface between the MSC and Base Station System (Iu\_CS interface)

The interface between the MSC and its BSS is specified in the 25.41x-series of Technical Specifications.

The BSS-MSC interface is used to carry information concerning:

- BSS management;
- call handling;
- mobility management;

### 6.2.1.3 Interface between the MSC and RNS (Iu\_CS interface)

The interface between the MSC and its RNS is specified in the 25.41x-series of Technical Specifications.

The RNS-MSC interface is used to carry information concerning:

- RNS management;
- call handling;
- mobility management.

## 6.2.2 Interfaces between the PS domain and the Access Network

### 6.2.2.1 Interface between SGSN and BSS (Gb-interface)

The BSS-SGSN interface is used to carry information concerning:

- packet data transmission;
- mobility management.

The Gb interface is defined in TS 48.014 [44], TS 48.016 [45] and TS 48.018 [46].

### 6.2.2.2 Interface between SGSN and BSS (Iu\_PS-interface)

The BSS-SGSN interface is used to carry information concerning:

- packet data transmission;
- mobility management.

The Iu\_PS interface is defined in the 25.41x-series of 3GPP Technical Specifications.

### 6.2.2.3 Interface between SGSN and RNS (Iu\_PS-interface)

The RNS-SGSN interface is used to carry information concerning:

- packet data transmission;
- mobility management.

The Iu\_PS interface is defined in the 25.41x-series of Technical Specifications.

## 6.2.3 Interfaces between the Evolved Packet Core and the Access Network

### 6.2.3.1 Interface between MME and E-UTRAN (S1-MME-interface)

Reference point for the control plane protocol between E-UTRAN and MME. This interface is defined in the TS 36.41x-series of Technical Specifications and in TS 24.301 [89].

### 6.2.3.2 Interface between S-GW and E-UTRAN (S1-U-interface)

Reference point between E-UTRAN and S GW for the per bearer user plane tunnelling. This interface is defined in TS 29.281 [126].

## 6.3 Interfaces internal to the Access Network

### 6.3.1 Interface between BSC and BTS (Abis-interface)

When the BSS consists of a Base Station Controller (BSC) and one or more Base Transceiver Stations (BTS), this interface is used between the BSC and BTS to support the services offered to the GSM users and subscribers.

The interface also allows control of the radio equipment and radio frequency allocation in the BTS.

The interface is specified in the 48.5x-series of Technical Specifications.

### 6.3.2 Interface between RNC and Node B (Iub-interface)

When the RNS consists of a Radio Network Controller (RNC) and one or more Node B, this interface is used between the RNC and Node B to support the services offered to the UMTS users and subscribers.

The interface also allows control of the radio equipment and radio frequency allocation in the Node B.

The interface is specified in the 25.43x series of Technical Specifications.

### 6.3.3 Interface between two RNCs (Iur-interface)

This interface is defined in the 25.42x series of Technical Specifications.

### 6.3.4 Interface between two eNBs (X2-interface)

This is a logical interface between two eNBs. Whilst logically representing a point to point link between eNBs, the physical realization need not be a point to point link. This interface is defined in the TS 36.42x-series of Technical Specifications.

### 6.3.5 Interface between HNB and HNB-GW (Iuh-interface)

This interface is specified in the TS 25.467 [114], TS 25.468 [115] and TS 25.469 [116].

## 6.4 Interfaces internal to the Core Network

### 6.4.1 Interfaces internal to the CS domain

#### 6.4.1.1 Interface between the MSC server and its associated VLR (B-interface)

The VLR is the location and management database for the mobile subscribers roaming in the area controlled by the associated MSC server(s). Whenever the MSC server needs data related to a given mobile station currently located in its

area, it interrogates the VLR. When a mobile station initiates a location updating procedure with an MSC server, the MSC server informs its VLR which stores the relevant information. This procedure occurs whenever an MS roams to another location area. Also, when a subscriber activates a specific supplementary service or modifies some data attached to a service, the MSC server informs (via the VLR) the HLR which stores these modifications and updates the VLR if required.

This interface is internal to the MSC server /VLR; signalling on it is not standardised.

#### 6.4.1.2 Interface between the HLR and the MSC server (C-interface)

The Gateway MSC server must interrogate the HLR of the required subscriber to obtain routing information for a call or a short message directed to that subscriber.

Signalling on this interface uses the Mobile Application Part (MAP), which in turn uses the services of Transaction Capabilities (see TS 29.002 [26]).

For CAMEL purposes, this interface is used as described in TS 23.078 [10c]. It is used e.g. at terminating calls to exchange routing information, subscriber status, location information, subscription information, etc.

#### 6.4.1.3 Interface between the HLR and the VLR (D-interface)

This interface is used to exchange the data related to the location of the mobile station and to the management of the subscriber. The main service provided to the mobile subscriber is the capability to set up or to receive calls within the whole service area. To support this, the location registers have to exchange data. The VLR informs the HLR of the location of a mobile station managed by the latter and provides it (either at location updating or at call set-up) with the roaming number of that station. The HLR sends to the VLR all the data needed to support the service to the mobile subscriber. The HLR then instructs the previous VLR to cancel the location registration of this subscriber. Exchanges of data may occur when the mobile subscriber requires a particular service, when he wants to change some data attached to his subscription or when some parameters of the subscription are modified by administrative means.

Signalling on this interface uses the Mobile Application Part (MAP), which in turn uses the services of Transaction Capabilities (see TS 29.002 [26]).

For CAMEL purposes, this interface is used to send the CAMEL related subscriber data to the visited PLMN and for provision of MSRN. The interface is also used for the other purposes described in TS 23.078 [10c], e.g. to retrieve subscriber status and location information of the mobile subscriber or to indicate suppression of announcement for a CAMEL service.

#### 6.4.1.4 Interface between MSC servers or MSC server and IP-SM-GW (E-interface)

When a mobile station moves from one MSC area to another during a call, a handover procedure has to be performed in order to continue the communication. For that purpose the MSC servers have to exchange data to initiate and then to realise the operation.

After the handover operation has been completed, the MSC servers will exchange information to transfer A- or Iu- interface signalling as defined in TS 23.009 [6].

When a short message is to be transferred between a Mobile Station and Short Message Service Centre (SC), in either direction, this interface is used to transfer the message between the MSC server serving the Mobile Station and the MSC server which acts as the interface to the SC. or between the IP-SM-GW serving the Mobile Station and the MSC server which acts as the interface to the SC.

Signalling on this interface uses the Mobile Application Part (MAP), which in turn uses the services of Transaction Capabilities (see TS 29.002 [26]).

#### 6.4.1.5 Interface between MSC server and EIR (F-interface)

This interface is used between MSC server and EIR to exchange data, in order that the EIR can verify the status of the IMEI retrieved from the Mobile Station.

Signalling on this interface uses the Mobile Application Part (MAP), which in turn uses the services of Transaction Capabilities (see TS 29.002 [26]).

#### 6.4.1.6 Interface between VLRs (G-interface)

When a mobile subscriber moves from a VLR area to another Location Registration procedure will happen. This procedure may include the retrieval of the IMSI and authentication parameters from the old VLR.

Signalling on this interface uses the Mobile Application Part (MAP), which in turn uses the services of Transaction Capabilities (see TS 29.002 [26]).

#### 6.4.1.7 Reference point (G)MSC server – CS-MGW (Mc Reference Point)

The Mc reference point describes the interfaces between the MSC Server and CS-MGW, and between the GMSC Server and CS-MGW. It has the following properties:

- full compliance with the H.248 [52] standard, baseline work of which is currently carried out in ITU-T Study Group 16, in conjunction with IETF MEGACO WG.
- flexible connection handling which allows support of different call models and different media processing purposes not restricted to H.323 [54] usage.
- open architecture where extensions/Packages definition work on the interface may be carried out.
- dynamic sharing of MGW physical node resources. A physical MGW can be partitioned into logically separate virtual MGWs/domains consisting of a set of statically allocated Terminations.
- dynamic sharing of transmission resources between the domains as the MGW controls bearers and manage resources according to the H.248 [52] protocols.

The functionality across the Mc reference point will need to support mobile specific functions such as SRNS relocation/handover and anchoring. It is expected that current H.248/IETF Megaco [52] standard mechanisms can be applied to enable this.

#### 6.4.1.8 Reference Point MSC Server – GMSC Server (Nc Reference Point)

Over the Nc reference point, the Network-Network based call control is performed. Examples of this are ISUP or an evolution of ISUP for bearer independent call control (BICC). Different options for signalling transport on Nc shall be possible including IP.

#### 6.4.1.9 Reference Point CS-MGW – CS-MGW (Nb Reference Point)

Over the Nb reference point the bearer control and transport are performed. The transport may be RTP/UDP/IP [59], [60] or AAL2 (I.363-2) [57] for transport of user data. Different options for user data transport and bearer control shall be possible on Nb, for example: AAL2/Q.AAL2, STM/none, RTP/H.245 [58], IPBC.

#### 6.4.1.10 Reference Point between the CSS and the VLR (Hv Reference Point)

This reference point is used to transfer to the VLR the CSG subscription information stored in the VPLMN for roaming UEs.

Signalling on this interface uses the Mobile Application Part (MAP), which in turn uses the services of Transaction Capabilities (TCAP) (see TS 29.002 [26]).

### 6.4.2 Interfaces internal to the PS domain (GPRS)

#### 6.4.2.1 Interface between SGSN and HLR (Gr-interface)

This interface is used to exchange the data related to the location of the mobile station and to the management of the subscriber. The main service provided to the mobile subscriber is the capability to transfer packet data within the whole service area. The SGSN informs the HLR of the location of a mobile station managed by the latter. The HLR sends to the SGSN all the data needed to support the service to the mobile subscriber. Exchanges of data may occur when the mobile subscriber requires a particular service, when he wants to change some data attached to his subscription or when some parameters of the subscription are modified by administrative means.

Signalling on this interface uses the Mobile Application Part (MAP), which in turn uses the services of Transaction Capabilities (TCAP) (see TS 29.002 [26]).

#### 6.4.2.2 Interface between SGSN and GGSN (Gn- and Gp-interface)

These interfaces are used to support mobility between the SGSN and GGSN. The Gn interface is used when GGSN and SGSN are located inside one PLMN. The Gp-interface is used if GGSN and SGSN are located in different PLMNs. The Gn/Gp interface also includes a part which allows SGSNs to communicate subscriber and user data, when changing SGSN.

Signalling on this interface uses the User Datagram Protocol, UDP/IP [59]. The Gn/Gp interface is defined in TS 29.060 [51].

#### 6.4.2.3 Signalling Path between GGSN and HLR (Gc-interface)

This optional signalling path may be used by the GGSN to retrieve information about the location and supported services for the mobile subscriber, to be able to activate a packet data network address.

There are two alternative ways to implement this signalling path:

- if an SS7 interface is implemented in the GGSN, signalling between the GGSN and the HLR uses the Mobile Application Part (MAP), which in turn uses the services of Transaction Capabilities (TCAP) (see TS 29.002 [26]);
- if there is *no* SS7 interface in the GGSN, any GSN in the same PLMN and which has an SS7 interface installed can be used as a GTP to MAP protocol converter, thus forming a signalling path between the GGSN and the HLR.

#### 6.4.2.4 Interface between SGSN and EIR (Gf-interface)

This interface is used between SGSN and EIR to exchange data, in order that the EIR can verify the status of the IMEI retrieved from the Mobile Station.

Signalling on this interface uses the Mobile Application Part (MAP), which in turn uses the services of Transaction Capabilities (TCAP) (see TS 29.002 [26]).

#### 6.4.2.5 Reference Point between the CSS and the Gn/Gp SGSN (Ghv Reference Point)

This reference point is used to transfer to the Gn/Gp SGSN the CSG subscription information stored in the VPLMN for roaming UEs.

Signalling on this interface uses the Mobile Application Part (MAP), which in turn uses the services of Transaction Capabilities (TCAP) (see TS 29.002 [26]).

### 6.4.3 Interfaces used by CS and PS domains

#### 6.4.3.1 Interface between MSC/VLR and SGSN (Gs-interface) for GPRS

The SGSN may send location information to the MSC/VLR via the optional Gs interface. The SGSN may receive paging requests from the MSC/VLR via the Gs interface. The MSC/VLR may indicate to an SGSN, via the Gs interface, that an MS is engaged in a service handled by the MSC.

Signalling on this interface uses connectionless SCCP (without TCAP). SCCP Global Title (GT) is used for addressing. The Gs-interface is defined in TS 29.016 [48] and TS 29.018 [49].

#### 6.4.3.2 Interface between HLR/HSS and AuC (H-Interface)

When an HLR/HSS receives a request for authentication and ciphering data for a Mobile Subscriber and it does not hold the requested data, the HLR/HSS requests the data from the AuC. The protocol used to transfer the data over this interface is not standardised.

### 6.4.3.3 Interface between SGSN/IP-SM-GW and SMS-GMSC/SMS-IWMSC (Gd/Gdd-Interface) for GPRS

The Gd interface may be used to transfer short messages between SGSN, IP-SM-GW and SMS-GMSC/SMS-IWMSC over GPRS.

Signalling on the Gd interface uses the Mobile Application Part (MAP) (see TS 29.002 [26]).

The Gdd interface may be used to transfer short messages between SGSN supporting EPS interfaces, IP-SM-GW and SMS GMSC/SMS IWMSC.

Signalling on the Gdd interface uses the Diameter SGd application (see TS 29.338 [135]).

### 6.4.3.4 Interface between MSC/VLR and MME (SGs-interface) for EPC

The SGs interface is the reference point between the MME and MSC/VLR which is used for the mobility management and paging procedures between EPS and CS domain, and it is based on the Gs interface procedures.

The SGs interface is used to provide Fallback for Location Services (LCS) and Call Independent Supplementary Services (SS).

The SGs interface is also used for the delivery of both mobile originating and mobile terminating SMS over EUTRAN in case SMSIP is not used.

The signalling on this interface uses SCTP. The SGs interface is defined in TS 23.272 [81] and TS 29.118 [82].

### 6.4.3.5 Interface between 3GPP MSC Server and MME or SGSN (Sv-interface)

The Sv reference point provides SRVCC support for functions like sending Forward Relocation Message between MME or SGSN and 3GPP MSC Server. This interface is specified in TS 29.280 [91].

## 6.4.4 Interfaces internal & related to the Evolved Packet Core

### 6.4.4.1 Interface between MME and HSS (S6a-interface)

This interface is used to exchange the data related to the location of the mobile station and to the management of the subscriber. The main service provided to the mobile subscriber is the capability to transfer packet data within the whole service area. The MME informs the HSS of the location of a mobile station managed by the latter. The HSS sends to the MME all the data needed to support the service to the mobile subscriber. Exchanges of data may occur when the mobile subscriber requires a particular service, when he wants to change some data attached to his subscription or when some parameters of the subscription are modified by administrative means.

Signalling on this interface uses Diameter S6a/S6d Application as specified in TS 29.272 [86].

### 6.4.4.2 Interface between SGSN and HSS (S6d-interface)

This interface is used to exchange the data related to the location of the mobile station and to the management of the subscriber. The main service provided to the mobile subscriber is the capability to transfer packet data within the whole service area. The SGSN informs the HSS of the location of a mobile station managed by the latter. The HSS sends to the SGSN all the data needed to support the service to the mobile subscriber. Exchanges of data may occur when the mobile subscriber requires a particular service, when he wants to change some data attached to his subscription or when some parameters of the subscription are modified by administrative means.

Signalling on this interface uses Diameter S6a/S6d Application as specified in TS 29.272 [86].

### 6.4.4.3 Interface between MME and S-GW (S11-interface)

This interface is used to support mobility and bearer management between the MME and S-GW. This interface is specified in TS 29.274 [90].

#### 6.4.4.4 Interface between MME and MME (S10-interface)

This interface is used to support user information transfer and MME relocation support between the MMEs. This interface is specified in TS 29.274 [90].

#### 6.4.4.5 Interface between S-GW and PDN GW (S5 and S8-interface)

These interfaces are between S-GW and PDN GW, provides support for functions for packet data services towards end users during roaming and non-roaming cases (i.e. S8 is the inter PLMN variant of S5). These interfaces are specified in TS 29.274 [90] and TS 29.281 [126] for GTP and TS 29.275 [93] for PMIP.

#### 6.4.4.6 Interface between MME and EIR (S13-interface)

This interface is used between MME and EIR to exchange data, in order that the EIR can verify the status of the IMEI retrieved from the Mobile Station.

Signalling on this interface uses the Diameter S13 Application, in TS 29.272 [86].

#### 6.4.4.7 Interface between MME and SGSN (S3-interface)

This interface enables user and bearer information exchange for inter 3GPP access network mobility in idle and/or active state. This interface is specified in TS 29.274 [90].

#### 6.4.4.8 Interface between S-GW and SGSN (S4-interface)

This interface provides related control and mobility support between GPRS Core and the 3GPP Anchor function of Serving GW. In addition, if Direct Tunnel is not established, it provides the user plane tunnelling. This interface is specified in TS 29.274 [90] and TS 29.281 [126].

#### 6.4.4.9 Interface between S-GW and UTRAN (S12-interface)

Reference point between UTRAN and Serving GW for user plane tunnelling when Direct Tunnel is established. It is based on the Iu-u/Gn-u reference point using the GTP-U protocol as defined between SGSN and UTRAN or respectively between SGSN and GGSN. Usage of S12 is an operator configuration option. This interface is specified in TS 29.281 [126].

#### 6.4.4.10 Interface between Trusted non-3GPP IP Access and S-GW/PDN GW (S2a-interface)

It provides the user plane with related control and mobility support between trusted non 3GPP IP access and the Gateway. This interface is specified in TS 29.275 [93] and TS 24.304 [94] for PMIP and Client Mobile IPv4 FA mode respectively. When GTP is used in S2a, this interface is specified in TS 29.274 [90] for GTP control plane (GTP-C) and in TS 29.281 [126] for GTP user plane (GTP-U).

#### 6.4.4.11 Interface between PDN GW/S-GW and ePDG (S2b-interface)

It provides the user plane with related control and mobility support between ePDG and the Gateway. This interface is specified in TS 29.274 [90] and TS 29.281 [126] for GTP and in TS 29.275 [93] for PMIP.

#### 6.4.4.12 Interface between PDN GW and UE (S2c-interface)

It provides the user plane with related control and mobility support between UE and the Gateway. This reference point is implemented over trusted and/or untrusted non-3GPP Access and/or 3GPP access. This interface is specified in TS 24.303 [95].

#### 6.4.4.13 Interface between PDN GW and 3GPP AAA Server/proxy (S6b-interface)

It is the reference point between PDN GW and 3GPP AAA server/proxy for mobility related authentication and authorization. This reference point may also be used to retrieve and request storage of mobility parameters, such as the

PDN GW Identity. This reference point may also be used to retrieve static QoS profile for a UE for non-3GPP access in case dynamic PCC is not supported. This interface is specified in TS 29.273 [96].

#### 6.4.4.14 Interface between Untrusted non-3GPP IP Access and 3GPP AAA Server/proxy (SWa-interface)

It enables support for the Untrusted non-3GPP IP Access with the 3GPP AAA Server/Proxy and transports access authentication, authorization and charging-related information in a secure manner. This interface is specified in TS 29.273 [96].

#### 6.4.4.15 Interface between Trusted non-3GPP IP Access and 3GPP AAA Server/proxy (STa-interface)

It connects the Trusted non-3GPP IP Access with the 3GPP AAA Server/Proxy and transports access authentication, authorization, mobility parameters and charging-related information in a secure manner. This interface is specified in TS 29.273 [96].

#### 6.4.4.16 Interface between 3GPP AAA Server and 3GPP AAA proxy (SWd-interface)

It connects the 3GPP AAA Proxy, possibly via intermediate networks, to the 3GPP AAA Server. This interface is specified in TS 29.273 [96].

#### 6.4.4.17 Interface between ePDG and 3GPP AAA Server/proxy (SWm-interface)

This reference point is located between 3GPP AAA Server/Proxy and ePDG and is used for AAA signalling (transport of mobility parameters, tunnel authentication and authorization data). This reference point also includes the MAG-AAA interface functionality and Mobile IPv6 NAS-AAA interface functionality. This interface is specified in TS 29.273 [96].

#### 6.4.4.18 Interface between ePDG and Untrusted non-3GPP Access (SWn-interface)

This is the reference point between the Untrusted Non-3GPP IP Access and the ePDG. Traffic on this interface for a UE-initiated tunnel has to be forced towards ePDG. This interface is specified in TS 29.273 [96].

#### 6.4.4.19 Interface between ePDG and UE (SWu-interface)

This is the reference point between the UE and the ePDG and supports handling of IPSec tunnels. The functionality of SWu includes UE-initiated tunnel establishment, user data packet transmission within the IPSec tunnel and tear down of the tunnel and support for fast update of IPSec tunnels during handover between two untrusted non-3GPP IP accesses. This interface is specified in TS 24.302 [97].

#### 6.4.4.20 Interface between HSS and 3GPP AAA Server (SWx-interface)

This reference point is located between 3GPP AAA Server and HSS and is used for transport of authentication data. This interface is specified in TS 29.273 [96].

#### 6.4.4.21 Interface between UE and ANDSF (S14-interface)

This reference point is between UE and ANDSF for direct queries via pull mechanism. It enables dynamic provision of information to the UE for Network discovery and selection procedures related to non-3GPP accesses. Push and/or combination of Pull-Push may be supported as well. This interface is specified in TS 24.302 [97].

#### 6.4.4.22 Reference point between HRPD AN and MME (S101-reference point)

The S101 interface supports procedures for Pre-Registration, Session Maintenance and Active handovers between E-UTRAN and HRPD networks. This is based on tunnelling over S101 signalling of one technology while the UE is in the other technology as specified in TS 23.402 [77]. The HRPD air interface messages tunnelled over S101 in E-UTRAN to HRPD mobility are defined in 3GPP2 C.S0087 0 [107].

#### 6.4.4.23 Reference point between 3GPP2 1xCS IWS and MME (S102-reference point)

The S102 reference point provides a tunnel between MME and 3GPP2 1xCS IWS to relay 3GPP2 1xCS signalling messages in order to support SRVCC as specified in TS 23.216 [83] and CS Fallback as specified in TS 23.272 [81]. 1x CS signalling messages are those messages that are defined for A21 interface as described in 3GPP2 A.S0008-C [106].

In case of CS Fallback to 1x CS network as specified in TS 23.272 [81], S102 Tunnel Redirection Procedure is used when the UE perform Tracking Area Update with MME change (as specified in TS 23.402 [77] in case of S101 tunnel redirection) while the UE is registered with the 1xRTT CS domain and the S102 session exists between the MME and the 1xCS IWS.

#### 6.4.4.24 Interface between HSGW and S-GW (S103-interface)

The S103 interface between the Serving GW and HRPD PDSN HSGW supports the forwarding of DL data during mobility from E-UTRAN to HRPD as specified in TS 23.402 [77]. Signalling procedures on the S101 interface are used to set up tunnels on the S103 interface.

#### 6.4.4.25 Reference point between UE and CSG List Server (Uh reference point)

This reference point is used to provision the Allowed CSG list and the Operator CSG list subscription information to the mobile station via OMA DM or OTA. This interface is specified in TS 24.285 [117] for OMA DM and in TS 31.102 [118] for OTA.

#### 6.4.4.26 Reference Point between the CSS and the S4-SGSN (S7d Reference Point)

This reference point is used to transfer to the S4-SGSN the CSG subscription information stored in the VPLMN for roaming UEs.

Signalling on this interface uses Diameter S7d Application as specified in TS 29.272 [86].

#### 6.4.4.27 Reference point between the CSS and the MME (S7a reference point)

This reference point is used to transfer to the MME the CSG subscription information stored in the VPLMN for roaming UEs.

Signalling on this interface uses Diameter S7a Application as specified in TS 29.272 [86].

#### 6.4.4.28 Reference point between the MME and the SMS-GMSC/SMS-IWMSC/SMS Router (SGd reference point)

This reference point is used to transfer short messages between the MME and SMS-GMSC, SMS-IWMSC or SMS Router. The details for this reference point are described in TS 23.040 [137] and TS 29.338 [135].

Signalling on this interface uses Diameter SGd Application as specified in TS 29.338 [135].

#### 6.4.4.29 Reference point between the HSS and the SMS-GMSC/SMS-IWMSC/SMS Router (S6c reference point)

This reference point is used to interrogate the HSS of the required subscriber to obtain routing information for a short message directed to that subscriber. The details for this reference point are described in TS 23.040 [137] and TS 29.338 [135].

Signalling on this interface uses Diameter S6c Application as specified in TS 29.338 [135].

#### 6.4.4.30 Reference point between HRPD AN and MME (S121-interface)

The S121 interface supports RIM message transfer between eNodeB and HRPD AN as described in TS 23.402 [77].

---

## 6a PLMN specific interfaces

### 6a.1 GCR-specific interface

#### 6a.1.1 Interface between the MSC and its associated GCR (I-interface)

The GCR is the management data base for the voice group or broadcast calls in the area controlled by the associated MSC(s). Whenever the MSC needs data related to a requested voice group or broadcast call it interrogates the GCR to obtain the respective voice group or broadcast call attributes. The protocol used to transfer the data over this interface is not standardized.

#### 6a.2 (void)

### 6a.3 LCS-specific interfaces

#### 6a.3.1 LCS interfaces using MAP

The following interfaces are based on MAP in LCS.

- **Lh interface:** interface between GMLC and HLR. This interface is used by the GMLC to request the address of the visited MSC or SGSN for a particular target UE whose location has been requested (see TS 29.002 [26]).
- **Lg interface:** interface between GMLC - MSC and GMLC - SGSN. This interface is used by the GMLC to convey a location request to the MSC or SGSN currently serving a particular target UE whose location was requested. The interface is used by the MSC or SGSN to return location results to the GMLC (see TS 29.002 [26]).
- **Lc interface:** between GMLC and gsmSCF, CAMEL. This interface is used to get location information for CAMEL based services. (see TS 29.002 [26]).

#### 6a.3.2 (void)

#### 6a.3.3 (void)

#### 6a.3.4 (void)

#### 6a.3.5 Interface between BSC and SMLC (Lb-interface)

In GERAN, a SMLC supports positioning via signalling on the Lb interface to the BSC serving the target MS.

Signalling on this interface uses BSSAP-LE, which is specified in TS 49.031 [50]

In UTRAN, the Lb interface is not standardized, the SMLC functionality is included in SRNC.

#### 6a.3.6 Interface between Peer SMLCs (Lp-interface)

In GERAN, a SMLC may support the Lp interface to enable access to information and resources owned by another SMLC.

Signalling on this interface uses BSSAPP-LE, which is defined in TS 49.031 [50], and SMLCPP, which is specified in TS 48.031 [47].

In UTRAN, the SMLC functionality is included in SRNC and the Iur interface shall include the Lp interface type of functionality.

### 6a.3.7 Interface between BTS and LMU (Um-interface)

The Um/Uu interface specific to LCS is defined in TS 44.071 [55].

### 6a.3.8 Interface between GMLC and External LCS Client (Le-interface)

The Le interface is used by the external LCS client to retrieve location information from the LCS server. Signalling on this interface may use the OMA Mobile Location Protocol (MLP) [62] and Open Service Access Application Programming Interface (OSA-API), TS 29.198 [63].

### 6a.3.9 Interface between RNS and Stand-Alone LMU, UE (Uu-interface)

The Uu interface is used to communicate among the UE Positioning entities associated with the SRNC, the UEs and the stand-alone LMU. The Uu interface may pass measurement requests and results to and from the UE or the stand-alone LMU. UE Positioning operations at the Uu interface are generally defined in the 24- and 25-series of 3GPP Technical Specifications. Furthermore, TS 25.305 [10b] describes how a stand-alone LMU may be distinguished from a normal UE.

### 6a.3.10 Interface between SRNC and SAS (Stand-Alone SMLC) (Iupc-interface)

The Iupc interface defined for LCS is specified in TS 25.453 [66].

### 6a.3.11 Interface between GMLC and GMLC (Lr-interface)

The Lr interface is used by the GMLC to communicate with other GMLCs. Signalling on this interface may use the OMA Roaming Location Protocol (RLP) [69].

### 6a.3.12 Interface between GMLC and MME (SLg-interface)

The SLg interface is used by the GMLC to communicate with MMEs. The SLg interface is defined in TS 29.172 [123].

### 6a.3.13 Interface between MME and E-SMLC (SLs-interface)

The SLs interface is used to convey LCS messages between the MME and E-SMLC. It is also used for tunnelling positioning protocol messages between the E-SMLC and either E-UTRAN or UE which are transparent to the MME as described in TS 36.305 [122]. The SLs interface is defined in TS 29.171 [124].

### 6a.3.14 Interface between GMLC and HSS (SLh-interface)

SLh interface between GMLC and HSS. This interface is used by the GMLC to request the address of the visited MME for a particular target UE whose location has been requested. The SLh interface is defined in TS 29.173 [125].

### 6a.3.15 Interface between GMLC and SGSN (Lgd-interface)

Lgd is the interface that is used by the GMLC to convey a location request to the SGSN currently serving a particular target UE whose location was requested. The interface is also used by the SGSN to return location results to the GMLC. This interface is applicable only for an SGSN supporting EPS based interfaces and protocols. The Lgd interface is defined in TS 29.172 [123].

## 6a.4 CAMEL-specific interfaces

The CAMEL-specific interfaces are detailed in TS 23.078 [10c]. These interfaces are.

### 6a.4.1 GMSC - gsmSSF interface

This is an internal interface. The interface is described in the specification to make it easier to understand the handling of Detection Points (arming/disarming of DPs, DP processing etc.).

### 6a.4.2 gsmSSF - gsmSCF interface

This interface is used by the gsmSCF to control a call in a certain gsmSSF and to request the gsmSSF to establish a connection with a gsmSRF. Relationships on this interface are opened as a result of the gsmSSF sending a request for instructions to the gsmSCF.

### 6a.4.3 MSC - gsmSSF interface

This is an internal interface. The interface is described in the specification to make it easier to understand the handling of DPs (arming/disarming of DPs, DP processing etc.).

### 6a.4.4 gsmSCF - HLR interface

This interface is used by the gsmSCF to request information from the HLR. As a network operator option the HLR may refuse to provide the information requested by the gsmSCF.

This interface is also used for USSD operations, both for gsmSCF-initiated dialogues and MS-initiated dialogues (relayed via HLR). It is a network operator option whether to support or not USSD operations on this interface.

### 6a.4.5 gsmSCF - gsmSRF interface

This interface is used by the gsmSCF to instruct the gsmSRF to play tones/announcements to the users.

### 6a.4.6 MSC - gsmSCF interface

This interface is used by the MSC to send supplementary service invocation notifications to the gsmSCF.

### 6a.4.7 SGSN - gprsSSF interface

This is an internal interface. The interface is described in the specification to make it easier to understand the handling of DPs (arming/disarming of DPs, DP processing etc.).

### 6a.4.8 gprsSSF - gsmSCF interface (Ge Reference Point)

This interface is used by the gsmSCF to control a GPRS session or individual PDP Context in a certain gprsSSF. Relationships between the gprsSSF and the gsmSCF (GPRS dialogues) on this interface are opened as a result of the gprsSSF sending a request for instructions to the gsmSCF. This interface is also known as Ge reference point (see TS 23.060 [9a]).

## 6a.5 CBS-specifTQq395(hi)1terf419(c)-6(e)15(s)] TJETBT1 0 0 27398.74

- CBS delivery parameter.

## 6a.5.2 Interface between the CBC and MME (SBc Interface)

Reference point between CBC and MME for warning message delivery and control functions. This interface is specified in TS 29.168 [98].

## 6a.5.3 Interface between the CBC and BSC

The interface between the CBC and the BSC is specified in TS 48.049 [119].

The CBC-BSC interface is used to carry information concerning:

- the CBS message and the warning message itself; and
- CBS message and warning message delivery parameters.

## 6a.6 Number portability specific interfaces

### 6a.6.1 IN-based solution

#### 6a.6.1.1 NPDB to MSC interface

Upon receiving an ISUP IAM, the (gateway or visited) MSC send a database query to the NPDB as a result of analysis of the received MSISDN. The MSISDN is included in the query to the NPDB. The NPDB determines whether the MSISDN is ported or not. If not, it responds back to the MSC to continue the normal call setup procedure for MT calls (optionally providing the Routing Number). If it is ported, the NPDB responds back to the MSC with a Routing Number pointing out the Subscription network.

### 6a.6.2 Signalling Relay-based solution

#### 6a.6.2.1 GMSC to MNP-SRF interface

Upon receiving an ISUP IAM, the gateway MSC sends a routing interrogation to the MNP-SRF, which in turn will perform one of the actions, described in clause 4a.7, depending on the portability status of the subscriber and the network configuration (see TS 23.066 [40]).

#### 6a.6.2.2 MNP-SRF to HLR interface

When the MNP-SRF receives a routing interrogation from the GMSC or an interrogating network entity (non/call related signalling), and it determines that the subscriber is not ported or it has been ported from another network, the MNP-SRF relays the message to the HLR.

## 6a.7 IM Subsystem Reference Points

### 6a.7.1 Reference Point HSS – CSCF (Cx Reference Point)

The Cx reference point supports information transfer between CSCF and HSS.

The main procedures that require information transfer between CSCF and HSS are

- 1) Procedures related to Serving CSCF assignment
- 2) Procedures related to routing information retrieval from HSS to CSCF
- 3) Procedures related to authorisation (e.g., checking of roaming agreement)

- 4) Procedures related to authentication: transfer of security parameters of the subscriber between HSS and CSCF
- 5) Procedures related to filter control: transfer of filter parameters of the subscriber from HSS to CSCF

Further information on the Cx reference point is provided in TS 23.228 [34].

### 6a.7.2 Reference Point CSCF – UE (Gm Reference Point)

The Gm reference point supports the communication between UE and IM CN subsystem, e.g. related to registration and session control.

The protocol used for the Gm reference point is SIP (as defined by RFC 3261 [61], other relevant RFC's, and additional enhancements introduced to support 3GPP's needs).

### 6a.7.3 Reference Point MGCF – IMS-MGW (Mn Reference Point)

The Mn reference point describes the interfaces between the MGCF and IMS-MGW in the IMS. It has the following properties:

- full compliance with the H.248 standard functions for IMS – PSTN/PLMN interworking.- flexible connection handling which allows support of different call models and different media processing purposes not restricted to H.323 [54] usage.
- open architecture where extensions/Packages definition work on the interface may be carried out.
- dynamic sharing of IMS-MGW physical node resources. A physical IMS-MGW can be partitioned into logically separate virtual MGWs/domains consisting of a set of statically allocated Terminations.
- dynamic sharing of transmission resources between the domains as the IMS- MGW controls bearers and manage resources according to the H.248 [52] protocols and functions for IMS.

### 6a.7.4 Reference Point MGCF – CSCF (Mg Reference Point)

The Mg reference point allows the MGCF to forward incoming session signalling (from the circuit switched network) to the CSCF for the purpose of interworking with circuit switched networks.

The protocol used for the Mg reference point is SIP (as defined by RFC 3261 [61], other relevant RFC's, and additional enhancements introduced to support 3GPP's needs).

### 6a.7.5 (void)

### 6a.7.5a Reference Point AS-MRFC for media control (Cr Reference Point)

The Cr reference point allows interaction between an Application Server and an MRFC for media control.

The Cr reference point enables the MRFC to fetch and cache documents and resources from an Application Server and to return data to an Application Server.

The Cr reference point enables media control protocol requests, responses and notifications to be sent between the MRFC and an Application Server.

Further information on the Cr reference point is provided in TS 23.218 [113].

### 6a.7.5b Reference Point AS-MRFC for session control (Mr' Reference Point)

The Mr' reference point allows interaction between an Application Server and an MRFC for session control without passing through an S-CSCF.

Further information on the Mr' reference point is provided in TS 23.218 [113].

### 6a.7.6 Reference Point CSCF - MRFC (Mr Reference Point)

The Mr reference point allows interaction between an S-CSCF and an MRFC.

The protocol used for the Mr reference point is SIP (as defined by RFC 3261 [61], other relevant RFC's, and additional enhancements introduced to support 3GPP's needs).

### 6a.7.6a Reference Point MRFC – MRFP (Mp Reference Point)

The Mp reference point allows an MRFC to control media stream resources provided by an MRF.

The Mp reference point has the following properties:

- Full compliance with the H.248 [52] standard.
- Open architecture where extensions (packages) definition work on the interface may be carried out.

### 6a.7.7 Reference Point CSCF – CSCF (Mw Reference Point)

The Mw reference point allows the communication and forwarding of signalling messaging between CSCFs, e.g. during registration and session control.

### 6a.7.8 (void)

### 6a.7.8a Reference Point CSCF – MRB (ISC Reference Point)

This interface is used with an MRB operating in In-Line mode and is described further in TS 23.218 [113]). The S-CSCF receives a session initiation request from an MRB that originated from an Application Server requesting MRF resources and whose destination is an MRF resource identified by the MRB. The S-CSCF routes the message to the identified MRFC. Subsequent messages in the same session dialog between the AS and MRFC traverse the MRB as well as the S-CSCF.

### 6a.7.9 (void)

### 6a.7.9a Reference Point AS – MRB (Rc Reference Point)

The Rc reference point is used by the AS to request that media resources be assigned to a call when utilizing an MRB in both Query and In-Line modes (as described in TS 23.218 [113]).

### 6a.7.10 Reference Point CSCF – BGCF (Mi reference point)

This reference point allows the Serving CSCF to forward the session signalling to the Breakout Gateway Control Function for the purpose of interworking to the circuit switched networks.

The Mi reference point is based on external specifications i.e. SIP [61].

### 6a.7.11 Reference Point BGCF – MGCF (Mj reference point)

This reference point allows the Breakout Gateway Control Function to exchange session signalling message with the Media Gateway Control Function for the purpose of interworking to the circuit switched networks, or for transit scenarios.

The Mj reference point is based on external specifications i.e. SIP [61].

### 6a.7.12 Reference Point BGCF/IBCF – BGCF (Mk reference point)

This reference point allows the Breakout Gateway Control Function/IBCF to forward the session signalling to another Breakout Gateway Control Function.

The Mk reference point is based on external specifications i.e. SIP [61].

### 6a.7.13 Reference Point CSCF- SLF (Dx Reference Point)

This interface between CSCF and SLF is used to retrieve the address of the HSS which holds the subscription for a given user or information related to a service.

This interface is not required in a single HSS environment. An example for a single HSS environment is a server farm architecture.

Details are described in TS 23.228 [34], clause 5.8.1.

### 6a.7.14 Reference Point to IMS media plane (Mb reference point)

The Mb reference point is used for IMS media transport between relevant IMS functions. IMS media is defined in some of the 26-series (e.g. TS 26.114 [143], TS 26.141 [144]).

### 6a.7.15 Reference Point S-CSCF – AS (ISC Reference Point)

This interface between Serving CSCF and the Application Servers (i.e., SIP Application Server, OSA Service Capability Server, or CAMEL IM-SSF) is used to provide services for the IMS.

Details are described in TS 23.228 [34], clause 4.2.4.

### 6a.7.15a Reference Point E-CSCF - EATF (I4 Reference Point)

This is the interface between the Emergency CSCF and the EATF in serving network (i.e. EATF as defined in TS 23.167 [74]), it is used to provide services for emergency sessions.

### 6a.7.15b Reference Point I-CSCF - EATF (I5 Reference Point)

This is the interface between the Interrogating CSCF and the EATF in serving network (i.e. EATF as defined in TS 23.167 [74]), it is used to provide services for emergency sessions.

### 6a.7.16 Reference Point HSS – SIP AS or OSA SCS (Sh Reference Point)

The Application Server (SIP Application Server and/or the OSA Service Capability Server) may communicate to the HSS. The Sh interface is used for this purpose. Details are described in TS 23.228 [34], clause 4.2.4.

This reference point is also used to exchange signalling between IP-SM-GW and the HSS for SMSIP delivery.

### 6a.7.17 Reference Point HSS – CAMEL IM-SSF (Si Reference Point)

The CAMEL Application Server (IM-SSF) may communicate to the HSS. The Si interface is used for this purpose. Details are described in TS 23.228 [34], clause 4.2.4.

### 6a.7.18 Reference Point UE – AS (Ut Reference Point)

The Ut interface resides between the UE and the SIP Application Server.

The Ut interface enables the user to manage information related to his services. Such as creation and assignment of Public Service Identities, management of authorization policies that are used e.g. by Presence service, conference policy management, etc.

The AS may need to exhibit security related functions for the Ut interface, the details of these security functions are described in TS 33.222 [72].

For the protocol at the Ut reference point HTTP shall be supported.

### 6a.7.19 Reference Point AS- SLF (Dh Reference Point)

This interface between AS and SLF is used to retrieve the address of the HSS which holds the subscription for a given user.

This interface is not required in a single HSS environment. An example for a single HSS environment is a server farm architecture.

Details are described in TS 23.228 [34], clause 5.8.1.

### 6a.7.20 Reference Point CSCF/BGCF - IBCF (Mx Reference Point)

The Mx reference point allows the communication and forwarding of signalling messages between a CSCF/BGCF and an IBCF, e.g. during session establishment.

### 6a.7.21 Reference Point IBCF - TrGW (Ix Reference Point)

This interface is used by the IBCF to control the TrGW, e.g. to request network address translation binding.

### 6a.7.22 Reference Point I-CSCF – AS (Ma Reference Point)

This interface between Interrogating-CSCF and the Application Servers (i.e. SIP Application Server, OSA Service Capability Server, or CAMEL IM-SSF) is used to:

- forward SIP requests destined to a Public Service Identity hosted by an Application Server directly to the Application Server. Details are described in TS 23.228 [34], clause 5.4.12; and
- initiate a request on behalf of a user or Public Service Identity, if the AS has no knowledge of the serving S-CSCF for that user or Public Service Identity. Details are described in TS 23.228 [34], clause 5.6.5.3.

### 6a.7.23 Reference Point P-CSCF – IMS Access Gateway (Iq Reference Point)

The Iq reference point is between the Proxy-CSCF and the IMS Access Gateway. It conveys the necessary information that is needed to allocate and release transport addresses.

Details are described in TS 23.228 [34], Annex G.

### 6a.7.23a Reference Point E-CSCF - LRF (MI Reference Point)

The MI reference point allows the E-CSCF to request the LRF to validate the location information received from the UE, to determine or query the LRF for routing information to emergency centres. Location information may be received from LRF and/or reference key to allow the PSAP to retrieve location at a later stage.

### 6a.7.24 Reference Point IBCF - IBCF (Ici Reference Point)

The Ici reference point allows two IBCFs to communicate with each other in order to provide the communication and forwarding of signalling messaging between IM CN subsystem networks.

### 6a.7.25 Reference Point TrGW - TrGW (Izi Reference Point)

The Izi reference point allows two TrGWs to forward media streams between IM CN subsystem networks.

## 6a.7.26 Void

## 6a.7.27 Reference Point MSC Server - CSCF (I2 Reference Point)

The I2 reference point is used to route session control signalling between the MSC Server and the IMS, as defined in TS 23.292 [110] and in TS 23.237 [111]. This can be a roaming and inter-operator reference point.

I2 is used to support one or more of the following features:

- An MSC Server enhanced for ICS, as defined in TS 23.292 [110].
- An MSC Server enhanced for ICS and SRVCC, as defined in TS 23.292 [110], TS 23.216 [83] and TS 23.237 [111].
- An MSC Server enhanced for ICS and SRVCC with the MSC Server assisted mid-call feature as defined in TS 23.237 [111].
- An MSC Server enhanced for ICS and SRVCC with the SRVCC for call in alerting phase feature as defined in TS 23.237 [111].

## 6a.7.28 Reference Point MSC Server - TAS (I3 Reference Point)

The I3 reference point is used between the MSC Server enhanced for ICS and the TAS to interwork CS signalling and communication service setting procedures, as defined in TS 23.292 [110].

## 6a.7.29 Reference Point ICS UE – SCC AS (I1 Reference Point)

The I1 reference point is used between the ICS UE and the SCC AS for service control signalling over CS access, as defined in TS 23.292 [110].

## 6a.7.30 Reference Point IBCF - Application Server (AS) (Ms Reference Point)

The Ms reference point is used between an IBCF and an AS for identity attestation, identity signing, and signature verification, as defined in TS 23.228 [34].

## 6a.8 Void

## 6a.9 Reference Points for 3GPP/WLAN Interworking

NOTE: With the introduction of Evolved Packet Core System, the 3GPP AAA server and 3GPP AAA Proxy provide a set of different and additional functions as specified in the EPC specific section of this specification.

### 6a.9.1 Reference point 3GPP AAA Server - HLR (D'/Gr' Reference Point)

This is the reference point between the 3GPP AAA server and the HLR up to and including Rel-4 and the HSS in Rel-5. The functionality of this reference point is similar to that of the Wx reference point. For more information see TS 23.234 [67].

### 6a.9.2 Reference point WLAN access network - 3GPP AAA Proxy/Server (Wa Reference Point)

This is the reference point between the WLAN access network and 3GPP AAA Proxy or Server. The AAA protocol on this reference point is used to transport authentication, authorization and charging data.

### 6a.9.3 Reference point 3GPP AAA Server – 3GPP AAA Proxy (Wd Reference Point)

This is the reference point between the 3GPP AAA Server and Proxy. the purpose of the protocols crossing this reference point is to transport authentication, authorization and related information. For more information see TS 23.234 [67].

### 6a.9.4 Reference point 3GPP AAA Server/Proxy - WAG (Wg Reference Point)

This is the reference point between the 3GPP AAA server/proxy and WAG. It is used to provide information needed by the WAG to perform policy enforcement functions for authorised users and to transport per-tunnel based charging information from the WAG to the AAA Proxy in roaming scenarios.

### 6a.9.5 Reference point PDG - packet data networks (Wi Reference Point)

This is the reference point between the PDG and a packet data network. It may be an operator external public or private packet data network or an intra operator packet data network, e.g. for provision of IMS services.

### 6a.9.6 Reference Point 3GPP AAA Server/Proxy - PDG (Wm Reference Point)

This is the reference point between the 3GPP AAA server/proxy and PDG. The functionality of this reference point is to enable:

- The 3GPP AAA Server/Proxy to retrieve tunnelling attributes and WLAN UE's IP configuration parameters from/via Packet Data Gateway
- Carrying messages for service authentication and authorization
- Carrying authentication data for the purpose of tunnel establishment, tunnel data authentication and encryption.

For more information see TS 23.234 [67].

### 6a.9.7 Reference Point WAG - WLAN access network (Wn Reference Point)

This is the reference point between the WAG and the WLAN access network. It is used to force traffic between a WLAN UE and PDG to go through the WAG.

### 6a.9.8 Reference Point WAG - PDG (Wp Reference Point)

This is the reference point between WAG and PDG. It is used to transport the Wu reference point protocol data packets.

### 6a.9.9 Reference point WLAN UE - PDG (Wu Reference Point)

This is the reference point between the 3GPP WLAN UE and PDG. The functionality of this reference point is to establish a tunnel between WLAN UE and PDG and to exchange data packets between WLAN UE and PDG.

### 6a.9.10 Reference point WLAN UE - WLAN access network (Ww Reference Point)

This is the reference point between the 3GPP WLAN UE and WLAN access network. The functionality of this reference point is specified by IEEE and outside the scope of 3GPP.

### 6a.9.11 Reference point 3GPP AAA Server - HSS (Wx Reference Point)

This is the reference point between the 3GPP AAA server and HSS. The functionality of this reference point is to enable:

- Retrieval of authentication vectors
- Retrieval of WLAN access-related subscriber information (profile)
- Registration of the 3GPP AAA Server of an authorised WLAN user in the HSS
- Indication of change of subscriber profile
- Retrieval of online charging / offline charging function addresses from HSS.
- Retrieval of service related information

For more information see TS 23.234 [67].

### 6a.9.12 Reference point 3GPP AAA Server - SLF (Dw reference point)

This reference point is between the 3GPP AAA Server and the SLF. The prime purpose of the protocol(s) crossing this reference point is to enable the 3GPP AAA Server to find the address of the HSS which holds the subscriber data for a given user identity in a configuration with multiple separately addressable HSSs.

## 6a.10 MBMS specific reference points for GPRS

### 6a.10.1 Reference point GGSN – BM-SC (Gmb Reference Point)

This reference point is used to exchange signalling between GGSN and BM-SC. This represents the network side boundary of the MBMS Bearer Service from a control plane perspective. This includes user specific Gmb signalling and MBMS bearer service specific signalling. The details for this reference point are described in TS 23.246 [70] and TS 29.061 [104].

### 6a.10.2 Reference point BM-SC – BM-SC (Mz Reference Point)

This reference point is the roaming variant of the Gmb reference point and is used to exchange signalling between a BM-SC in the VPLMN and a BM-SC in the HPLMN. The details for this reference point are described in TS 23.246 [70] and TS 29.061 [104].

### 6a.10.3 Reference point GGSN – RNS (or BSS Iu mode) (Gmc Reference Point)

This reference point is used between GGSN and RNS (or BSS Iu mode) for MBMS data delivery using IP multicast. The details for this reference point are described in TS 23.246 [70] and TS 29.281 [126].

## 6a.11 MBMS specific reference points for EPS

### 6a.11.1 Reference point MBMS-GW – BM-SC (SGmb Reference Point)

This reference point is used to exchange signalling between MBMS-GW and BM-SC. This represents the network side boundary of the MBMS Bearer Service from a control plane perspective. This includes MBMS bearer service specific signalling. The details for this reference point are described in TS 23.246 [70] and TS 29.061 [104].

### 6a.11.2 Reference point MBMS-GW – BM-SC (SGi-mb Reference Point)

This reference point is used between MBMS-GW and BM-SC for MBMS data delivery. The details for this reference point are described in TS 23.246 [70] and TS 29.061 [104].

### 6a.11.3 Reference point MBMS-GW - MME (Sm Reference Point)

This reference point is used to exchange signalling between MBMS-GW and MME for MBMS Session Control. The details for this reference point are described in TS 23.246 [70] and TS 29.274 [90].

### 6a.11.4 Reference point MBMS-GW – SGSN (Sn Reference Point)

This reference point is used to exchange signalling between MBMS-GW and S4-SGSN for MBMS Session Control and for MBMS data delivery in point-to-point mode. The details for this reference point are described in TS 23.246 [70] and TS 29.274 [90].

### 6a.11.5 Reference point MBMS-GW – E-UTRAN/UTRAN (M1 Reference Point)

This reference point is used between MBMS-GW and E-UTRAN/UTRAN for MBMS data delivery using IP Multicast. The details for this reference point are described in TS 23.246 [70], TS 29.281 [126] and TS 36.445 [129].

### 6a.11.6 Reference point MME – MCE (M3 Reference Point)

This reference point is used to exchange signalling between MME and MCE for MBMS Session Control. The details for this reference point are described in TS 23.246 [70], TS 36.300 [78] and TS 36.444 [128].

### 6a.11.7 Reference point MCE - eNodeB (M2 Reference Point)

This reference point is used to exchange signalling between MCE and eNodeB for MBMS Session Control. The details for this reference point are described in TS 23.246 [70], TS 36.300 [78] and TS 36.443 [127].

### 6a.11.8 Reference point Content Provider/SCEF - BM-SC (xMB Reference Point)

This reference point is used to exchange signalling between Content Provider and BM-SC, either directly or via SCEF and to exchange application data directly between Content Provider and BM-SC. The details for this reference point are described in TS 26.346 [146].

## 6a.12 Reference Points for 3GPP Generic User Profile (GUP)

### 6a.12.1 Reference Point GUP Server – Applications (Rg Reference Point)

The Rg reference point resides between the GUP Server and the Applications.

The Rg reference point allows applications to create, read, modify and delete any user profile data using the harmonized access interface. The GUP Server locates the data repositories responsible of the storage of the requested profile component(s).

The details of the Rg reference point are described in TS 23.240 [71].

### 6a.12.2 Reference Point GUP Server – HSS and Applications – HSS (Rp Reference Point)

The Rp reference point resides between the GUP Server and the HSS, and between the Applications and the HSS.

The Rp reference point enables the GUP Server and the Applications to access GUP Data Repositories. The HSS is one of the GUP Data Repositories. It stores the IM CN Subsystem user related data.

The details of the Rp reference point are described in TS 23.240 [71].

## 6a.13 Reference Points for Policy and Charging Control

### 6a.13.1 Reference Point PCEF - PCRF/H-PCRF/V-PCRF (Gx Reference Point)

This interface provides transfer of policy and charging rules from PCRF to Policy and Charging Enforcement Function Point (PCEF) in the GW (e.g. GGSN, PDN GW). This interface is specified in TS 29.212 [99].

### 6a.13.2 Reference Point PCRF - Application Function (Rx Reference Point)

This interface allows for dynamic QoS and charging-related service information to be exchanged between the Policy and Charging Rules Function (PCRF) and the Application Function (AF). This information is used by the PCRF for the control of service data flows and IP bearer resources. For more information see TS 23.203 [73].

### 6a.13.3 Reference Point SPR – PCRF (Sp Reference Point)

This interface allows for the PCRF to request subscription information from the SPR and the SPR to notify the PCRF when the subscription information has changed if the PCRF has requested such notifications. The details associated with the Sp reference point are not specified in this Release.

### 6a.13.4 Reference Point OCS – PCEF (Gy Reference Point)

This interface allows for the online charging based on the Diameter credit control application between the Online Charging System (OCS) and the PCEF. For more information see TS 32.251 [101] and RFC 4006 [102].

### 6a.13.5 Reference Point OFCS – PCEF (Gz Reference Point)

This interface allows for the offline charging based on the charging record data transfer between the Offline Charging System (OFCS) and the PCEF. For more information see TS 32.295 [109].

### 6a.13.6 Reference Point Trusted non-3GPP IP Access and PCRF/VPCRF (Gxa Reference Point)

This interface provides transfer of (QoS) policy information from PCRF to the Trusted Non-3GPP accesses. This interface is specified in TS 29.212 [99].

### 6a.13.7 Reference Point ePDG and PCRF/VPCRF (Gxb Reference Point)

This interface is not specified within this release of the specification.

### 6a.13.7a Reference Point ePDG and PCRF/VPCRF (Gxb\* Reference Point)

The reference point transports access information from ePDG to PCRF/vPCRF for WLAN UEs such as the UE local IP address and the UDP port number. This interface is specified in TS 29.212 [99].

Gxb\* is only applicable to the interworking with Fixed Broadband Access network.

### 6a.13.8 Reference point between S-GW and PCRF/VPCRF (Gxc-interface)

This interface provides transfer of (QoS) policy information from PCRF to the Serving Gateway, Gxc is used only in the case of PMIP-based S5/S8. This interface is specified in TS 29.212 [99].

### 6a.13.9 Reference Point PCRF/VPCRF – BBERF (Gxx Reference Point)

This interface allows for a PCRF to have a dynamic control over the Bearer Binding and Event Report Function (BBERF) behaviour. For more information see TS 23.402 [77] and TS 23.203 [73]. This interface is specified in TS 29.213 [92]

### 6a.13.10 Reference Point HPCRF - VPCRF (S9- interface)

This interface provides transfer of policy and charging rules (in case of local breakout of traffic) and/or (QoS) policy information (when Gxx interface applies) between the Home PCRF and the Visited PCRF in order to support PCC roaming related functions. This interface is specified in TS 29.215 [103].

### 6a.13.11 Reference Point UDR – PCRF (Ud Reference Point)

This interface allows for the PCRF, acting as an UDC Application Frontend as defined in TS 23.335 [120], to request subscription information from the UDR and the UDR to notify the PCRF when the subscription information has changed if the PCRF has requested such notifications. For details regarding the Ud reference point see TS 23.335 [120] and TS 29.335 [121].

### 6a.13.12 Reference Point TDF - PCRF/H-PCRF/V-PCRF (Sd Reference Point)

The Sd Reference Point enables a PCRF to have dynamic control over the application detection and control behaviour at a TDF. The Sd Reference Point is specified in TS 29.212 [99].

### 6a.13.13 Reference Point OCS - PCRF/H-PCRF (Sy Reference Point)

The Sy Reference Point enables transfer of information relating to subscriber spending from OCS to PCRF. The Sy Reference Point is specified in TS 29.219 [131].

### 6a.13.14 Reference Point HNB GW - PCRF/V-PCRF (S15 Reference Point)

This reference point supports the initiation, modification and termination of sessions between the HNB GW and PCRF to support CS sessions. It triggers the PCRF to request allocation of resources in the Fixed Broadband access network for HNB CS calls. This interface is specified in TS 29.212 [99].

S15 is only applicable to the interworking with Fixed Broadband Access network.

### 6a.13.15 Reference Point BPCF - PCRF/v-PCRF (S9a Reference Point)

This interface supports the transfer of (QoS) policy information from PCRF to BPCF of broadband access network. This interface is specified in TS 29.215 [103].

S9a is only applicable to the interworking with Fixed Broadband Access network.

### 6a.13.16 Reference Point OCS - TDF (Gyn Reference Point)

The Gyn Reference Point allows for the online charging based on the Diameter credit control application between the Online Charging System (OCS) and the TDF. For more information see TS 32.251 [101] and RFC 4006 [102].

### 6a.13.17 Reference Point OFCS - TDF (Gzn Reference Point)

The Gzn Reference Point allows for the offline charging based on the charging record data transfer between the Offline Charging System (OFCS) and the TDF. For more information see TS 32.295 [109].

### 6a.13.18 Void

### 6a.13.19 Reference Point TSSF - PCRF/H-PCRF (St Reference Point)

The St Reference Point enables a PCRF to have dynamic control over the traffic steering behaviour at a TSSF. The St Reference Point is specified in TS 29.212 [99].

### 6a.13.20 Reference point between PFDF and PCEF (Gw reference point)

The Gw reference point enables the PFDF to provide PFDs to the PCEF as described in TS 23.203 [73].

### 6a.13.21 Reference point between PFDF and TDF (Gwn reference point)

The Gwn reference point enables the PFDF to provide PFDs to the TDF as described in TS 23.203 [73].

## 6a.14 SMSIP specific reference points

### 6a.14.1 Reference point IP-SM-GW – HSS (J Reference Point)

This reference point is used to exchange signalling between IP-SM-GW and the HSS for SMSIP delivery. The details for this reference point are described in TS 23.204 [75].

## 6a.15 User Data Convergence specific reference points

### 6a.15.1 Reference point Application Front Ends - UDR (Ud Reference Point)

This reference point is used to exchange user between Application Front Ends and the UDR. The details for this reference point are described in TS 23.335 [120] and TS 29.335 [121].

## 6a.16 Specific reference points for facilitating communications with packet data networks and applications

### 6a.16.1 Reference point MTC-IWF - SCS (Tsp reference point)

This reference point is used between the MTC-IWF and the Services Capability Server (SCS) to invoke specific functionalities in the PLMN such as device triggering. The details for this reference point are described in TS 23.682 [132] and TS 29.368 [136].

This interface is a PLMN internal interface if the SCS is controlled by the operator.

Signalling on this interface uses Diameter Tsp Application as specified in TS 29.368 [136].

NOTE: See clause 7.8 when the SCS is not controlled by the operator.

### 6a.16.2 Reference point MTC-IWF - HSS/HLR (S6m reference point)

This reference point is used between the MTC-IWF and the HSS/HLR to authorize a certain SCS to request a specific service (e.g. device triggering), and to retrieve subscription information and routing information (i.e. serving SGSN/MME/MS-CSCF identities) from the HSS/HLR.

The details for this reference point are described in TS 23.682 [132] and TS 29.336 [133].

Signalling on this interface uses Diameter S6m Application as specified in TS 29.336 [133].

### 6a.16.3 Reference point MTC-AAA - HSS/HLR (S6n reference point)

This reference point is used between the MTC-AAA and the HSS/HLR to translate an IMSI to external identifier(s) of the user.

The details for this reference point are described in TS 23.682 [132] and TS 29.336 [133].

Signalling on this interface uses Diameter S6n Application as specified in TS 29.336 [133].

### 6a.16.4 Reference point MTC-IWF - SMS-SC (T4 reference point)

This reference point is used between the MTC-IWF and the SMS-SC to transfer device trigger to the SMS-SC inside the HPLMN.

The details for this reference point are described in TS 23.682 [132] and TS 29.337 [134].

Signalling on this interface uses Diameter T4 Application as specified in TS 29.337 [134].

### 6a.16.5 Reference point between the HSS and the SCEF (S6t reference point)

The S6t reference point is defined between the SCEF and the HSS. It provides general access to the capabilities and data of the HSS from the SCEF, including configuration and reporting of specific monitoring events.

The details for this reference point are described in TS 23.682 [132].

### 6a.16.6 Reference point between the MME and the SCEF (T6a reference point)

The T6a reference point is defined between the SCEF and the MME. It provides general access to the capabilities of the MME from the SCEF, including configuration and reporting of specific monitoring events.

The details for this reference point are described in TS 23.682 [132].

### 6a.16.7 Reference point between the SGSN and the SCEF (T6b reference point)

The T6b reference point is defined between the SCEF and the SGSN. It provides general access to the capabilities of the SGSN from the SCEF, including configuration and reporting of specific monitoring events.

The details for this reference point are described in TS 23.682 [132].

### 6a.16.8 Reference point between the RCAF and the SCEF (Ns reference point)

The Ns reference point is defined between the SCEF and the RCAF. It allows the SCEF to request and consequently be notified of the network status.

The details for this reference point are described in TS 23.682 [132].

### 6a.16.9 Reference point between the PCRF and the SCEF (Nt reference point)

This reference point allows for negotiation about the recommended time window(s) and the related conditions for future background data transfer between the Policy and Charging Rules Function (PCRF) and the Service Capability Exposure Function (SCEF). For more information see TS 23.203 [73].

### 6a.16.10 Reference point between the PFDF and the SCEF (Nu reference point)

This reference point enables the Service Capability Exposure Function (SCEF) to manage Packet Flow Descriptions (PFDs) in the Packet Flow Description Function (PFDF) according to the instructions received from the SCS/AS. For more information see TS 23.682 [132].

## 6a.17 GCSE\_LTE specific reference points

### 6a.17.1 Reference point GCS AS - BM-SC (MB2 Reference Point)

This reference point is used to exchange signalling and application data between BM-SC and GCS AS. This includes start, stop, and modification of MBMS broadcast bearer service. The details for this reference point are described in TS 23.468 [140].

### 6a.17.2 Reference point GCS AS - UE (GC1 Reference Point)

This reference point is used to exchange signalling and application data between GCS AS and UE. The details for this reference point are described in TS 23.468 [140].

## 6a.18 ProSe specific reference points

### 6a.18.1 Reference point UE - ProSe Application Server (PC1 Reference Point)

This reference point is used to define application level signalling requirements. This reference point is not specified in this release of the specification. The details for this reference point are described in TS 23.303 [141].

### 6a.18.2 Reference point ProSe Function - ProSe Application Server (PC2 Reference Point)

This reference point is used to define the interaction between ProSe Application Server and ProSe functionality provided by the 3GPP EPS via ProSe Function (e.g. name translation) for EPC-level ProSe discovery. The details for this reference point are described in TS 23.303 [141].

### 6a.18.3 Reference point UE - ProSe Function (PC3 Reference Point)

This reference point relies on EPC user plane for transport (i.e. an "over IP" reference point). It is used to authorise ProSe Direct Discovery and EPC-level ProSe Discovery requests, and perform allocation of ProSe Application Codes corresponding to ProSe Application Identities used for ProSe Direct Discovery. It is used to define the authorisation policy per PLMN for ProSe Direct Discovery (for Public Safety and non -Public Safety) and communication (for Public Safety only) between UE and ProSe Function. The details for this reference point are described in TS 23.303 [141].

#### 6a.18.4 Reference point HSS - ProSe Function (PC4a Reference Point)

The reference point is used to provide subscription information in order to authorise access for ProSe Direct Discovery and ProSe Direct Communication on a per PLMN basis. It is also used by the ProSe Function (i.e. EPC-level ProSe Discovery Function) for retrieval of EPC-level ProSe Discovery related subscriber data. The details for this reference point are described in TS 23.303 [141].

#### 6a.18.5 Reference point SLP - ProSe Function (PC4b Reference Point)

The reference point is used by the ProSe Function (i.e. EPC-level ProSe Discovery Function) (in the role of LCS client) to query the SLP defined in OMA AD SUPL [80]. The details for this reference point are described in TS 23.303 [141].

#### 6a.18.6 Reference point UE - UE (PC5 Reference Point)

This reference point is between ProSe-enabled UEs used for control and user plane for ProSe Direct Discovery, ProSe Direct Communication and ProSe UE-to-Network Relay. The details for this reference point are described in TS 23.303 [141].

#### 6a.18.7 Reference point ProSe Function - ProSe Function in different PLMNs (PC6 Reference Point)

This reference point is between ProSe Functions in different PLMNs (EPC-level ProSe Discovery) or between the ProSe Function in the HPLMN and the ProSe Function in a Local PLMN (ProSe Direct Discovery). With ProSe Direct Discovery this reference point is used for HPLMN control of ProSe service authorization. It is also used to authorise ProSe Direct Discovery requests, retrieve the Discovery Filter(s) corresponding ProSe Application ID name(s) and translate the ProSe Application Code to the ProSe Application ID Name. The details for this reference point are described in TS 23.303 [141].

#### 6a.18.8 Reference point ProSe Function in HPLMN - ProSe Function in VPLMN (PC7 Reference Point)

This reference point is between the ProSe Function in the HPLMN and the ProSe Function in the VPLMN. It is used for HPLMN control of ProSe service authorization. It is also used to authorise ProSe Direct Discovery requests, retrieve the Discovery Filter(s) corresponding ProSe Application ID name(s) and translate the ProSe Application Code to the ProSe Application ID Name. The details for this reference point are described in TS 23.303 [141].

### 6a.19 Reference points for RAN user plane congestion detection and reporting

#### 6a.19.1 Reference Point RCAF - PCRF/ V-PCRF (Np Reference Point)

The Np Reference Point enables transport of RAN User Plane Congestion Information sent from the RCAF to the PCRF. The Np Reference Point is specified in TS 23.203 [73].

#### 6a.19.2 Reference point between MME and RCAF (Nq reference point)

The Nq reference point enables the RCAF to retrieve the list of UEs (identified by the IMSIs) served by an eNB or E-UTRAN cell and the list of APNs of the active PDN connections of each IMSI. The Nq reference point is specified in TS 23.401 [76].

#### 6a.19.3 Reference point between SGSN and RCAF (Nq' reference point)

The Nq' reference point enables the RCAF to retrieve the list of APNs of the active PDN connections of a given UE (identified by the IMSI). The Nq' reference point is specified in TS 23.060 [9a].

---

## 7 Reference points between the PLMN and other networks

The reference points between the PLMN and other networks, including dedicated networks, are described in the 49-series of Technical Specifications and in the 29-series of Technical Specifications.

### 7.1 Reference point fixed networks - MSC

The MSC is based on a normal ISDN exchange. It has, for call control, the same reference points as the fixed network exchanges. The signalling reference point considered in the Technical Specifications is related to the signalling system No. 7 User Parts TUP and ISUP associated to the circuits used for incoming and outgoing calls.

### 7.2 Reference point GGSN - packet data networks (Gi reference point)

This is the reference point between the GGSN and a packet data network. It may be an operator external public or private packet data network or an intra operator packet data network, e.g. for provision of IMS services.

### 7.2a Reference point PDN GW - packet data networks (SGi reference point)

This is the reference point between the PDN GW and a packet data network. It may be an operator external public or private packet data network or an intra operator packet data network, e.g. for provision of IMS services. For more details see TS 29.061 [104].

### 7.3 Reference point GMLC - external LCS Client (Le reference point)

At this reference point external LCS Clients request services from the PLMN.

### 7.4 Reference Point CSCF/IBCF – Multimedia IP networks (Mm Reference Point)

This is an IP interface between CSCF/IBCF and IP networks. This interface is used, for example, to receive a session request from another SIP server or terminal.

### 7.5 (void)

### 7.6 Reference point PDG - packet data networks (Wi reference point)

This is the reference point between the PDG and a packet data network. It may be an operator external public or private packet data network or an intra operator packet data network, e.g. for provision of IMS services.

## 7.7 Reference Point WAG – WLAN access network (Wn reference point)

This is the reference point between the WAG and the WLAN access network. It is used to force traffic between a WLAN UE and PDG to go through the WAG.

## 7.8 Reference point MTC-IWF - SCS (Tsp reference point)

See clause 6a.16.1.

This interface is an interface between the PLMN and other networks if the SCS is not controlled by the operator.

---

## Annex A (informative): Description for GLR-related entities and interfaces

This annex describes the GLR-related entities and the interfaces. This annex is an informative annex. The 'informative' means just that the GLR is an optional functional entity to optimize signalling traffic between PLMNs. Therefore, this annex is normative to a PLMN which introduce the GLR.

The GLR is only applicable for GERAN and UTRAN access. The GLR is not applicable to the EPC.

---

### A.1 Normative references

- [A1] 3GPP TS 23.119: "3rd Generation Partnership Project; Technical Specification Group Core Network; Gateway Location Register (GLR); Stage2".
- 

### A.2 Definitions related to Gateway Location Register (GLR)

#### A.2.1 Gateway Location Register (GLR)

This entity handles location management of roaming subscriber in visited network without involving HLR. The location register function in the GLR stores subscription information and routing information for both CS services and PS services. This entity can be only located in a visited PLMN.

#### A.2.2 Intermediate Mobile-services Switching Centre (IM-MSC)

This entity is used as serving MSC towards home network and relay some messages between home network and serving MSC. This entity can be only located in a visited PLMN.

#### A.2.3 Intermediate GPRS Serving Node (IM-GSN)

This entity is used as serving GSN towards home network and relay some PDU notification messages between serving GSN and Gateway GSN. This entity can be only located in a visited PLMN.

---

### A.3 The entities of the mobile system

#### A.3.1 Gateway Location Register (GLR)

GLR is pseudo-HLR located in visited network. The roamer's information is stored in it and handles location management of it within the network. Presence of GLR is invisible from home network therefore interface between HLR and GLR is same as one of HLR and VLR. Also, the interface between the VLR and GLR is the same as the one between the VLR and the HLR.

The GLR is a logical node and acts as a VLR for MAP signalling (e.g. PRN) from the HPLMN point of view. The GLR acts as a HLR for MAP signalling (e.g. Register SS) from the VPLMN point of view.

The GLR also acts as an SGSN for MAP signalling only (e.g. ISD) from the HPLMN point of view. This is because MAP operations such as ISD must be terminated at the GLR for the purpose of subscriber data caching.

The GLR shall terminate all TC dialogues and start new dialogues towards the HLR or the VLR. The GLR shall generate SCCP address of the HLR (i.e. E.214 MGT) from IMSI.

## A.3.2 Intermediate Mobile-services Switching Centre (IM-MSC)

The Intermediate MSC (IM-MSC) is the logical node, which represent MSCs in the visited network. Some service features use the MSC Number stored in the HLR directly to deliver message from a certain node in home network (e.g. SMS-GMSC) to serving MSC in visited network. In such case, the message is firstly distributed to representative MSC (i.e. IM-MSC) and it relays it to actual serving MSC interrogating routing information to GLR.

- The Intermediate MSC (IM-MSC) is a logical node and represents the VMSC in the GLR equipped VPLMN.
- The IM-MSC acts as the VMSC for the HPLMN in the same way that the GLR acts as a VLR for HPLMN. The IM-MSC terminates MAP signalling from the HPLMN towards the VMSC and forwards the signal to the actual VMSC.
- The IM-MSC has an address interrogation function with which it is able to obtain the actual VMSC Number from the GLR.
- The IM-MSC is implemented in the same physical node as the one in which the GLR is implemented.
- The GLR alters the VMSC Number to the IM-MSC Number within an Update Location message.
- The IM-MSC Number is the E.164 Number assigned to the IM-MSC [53].
- The interrogation function of the IM-MSC is similar to that in the SMS-GMSC.

## A.3.3 Intermediate GPRS Serving Node (IM-GSN)

The Intermediate GSN (IM-GSN) is a logical node and represents the SGSN for some GTP signalling termination in a GLR equipped VPLMN.

The IM-GSN acts as an SGSN for *only some GTP signalling messages* (i.e. PDU\_Notification request/response, PDU\_Notification\_reject request/response) from the HPLMN point of view. The IM-GSN terminates these GTP signalling messages from the HPLMN towards SGSN and forwards the signal to the actual SGSN. The IM-GSN has an address interrogation function with which it is able to request the actual SGSN address from the GLR.

Apart from the case described above (i.e. PDU\_Notification request/response, PDU\_Notification\_reject request/response), all other GTP signalling should be handled directly between the SGSN and the GGSN.

NOTE: *MAP signalling* towards the SGSN is *NOT* terminated at the IM-GSN. Instead it is terminated at the GLR.

---

# A.4 Configuration of a Public Land Mobile Network

## A.4.1 Basic configuration with GLR introduction

In the basic configuration with GLR introduction presented in figure A.1, all the functions related to GLR introduction are considered implemented in different equipments. Therefore, all the interfaces within PLMN are external. Interfaces GLa, GLb, GLc, GLd, GLf, GLg, GLh, and GLi need the support of the Mobile Application Part of the signalling system No. 7 to exchange the data necessary to provide the mobile service. No protocols for the GLe interface are standardized. GLj and GLk need the support of GPRS Tunnelling Protocol - Control to provide the packet domain services.

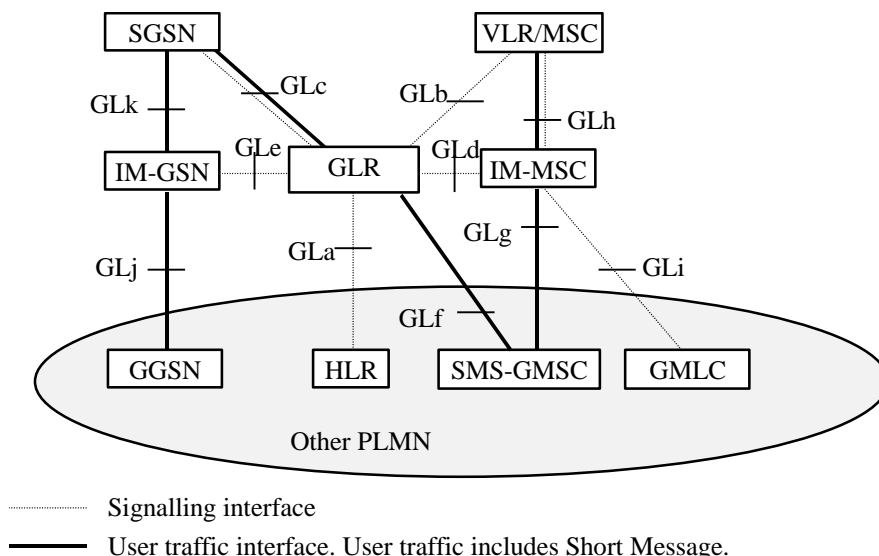

**Figure A.1: Configuration of a PLMN and interfaces with GLR**

## A.5 PLMN interfaces

### A.5.1 Interface between the HLR and the GLR (GLa-interface)

In circuit switched domain, this interface is the same as that between the VLR and the HLR (see TS 29.002 [26]). The HLR regards the GLR as the VLR via this interface. On the other hand, in packet switched domain, this interface is the same as that between the SGSN and the HLR (see TS 29.002 [26]). The HLR regards the GLR as the SGSN via this interface.

### A.5.2 Interface between the VLR and the GLR (GLb-interface)

This interface is the same as those between the VLR and the HLR (see TS 29.002 [26]). The VLR regards the GLR as the HLR via this interface.

### A.5.3 Interface between the SGSN and the GLR (GLc-interface)

This interface is the same as those between the SGSN and the HLR (see TS 29.002 [26]). The SGSN regards the GLR as the HLR via this interface.

### A.5.4 Interface between the GLR and the IM\_MSC (GLd-interface)

In the network with the GLR, when the IM\_MSC receives a message, it interrogates the GLR for the routing information of the MSC. However, this interface is internal because GLR and IM-MSC are implemented in the same physical node and the protocol on this interface is not specified.

### A.5.5 Interface between the GLR and the IM\_GSN (GLE-interface)

In the network with the GLR when the IM\_GSN receiving a PDU notification from the GGSN, the IM\_GSN relays the notification to the SGSN by interrogating via the interface the routing information to the GLR. The interrogation uses the same operation on the interface between the SGSN and the HLR (see TS 29.002 [26]).

## A.5.6 Interface between the SMS-GMSC and the GLR (GLf-interface)

This interface is used to forward mobile-terminated short messages in the network with the GLR in case of SMS transfer over GPRS. Signalling on this interface uses the Mobile Application Part (MAP) (see TS 29.002 [26]).

The SMS-GMSC regards the GLR as the SGSN via this interface.

## A.5.7 Interface between the SMS-GMSC and the IM\_MSC (GLg-interface)

This interface is used to forward short messages in the network with the GLR in case of SMS transfer over non-GPRS. Signalling on this interface uses the Mobile Application Part (MAP) (see TS 29.002 [26]).

The SMS-GMSC regards the IM\_MSC as the MSC via this interface.

## A.5.8 Interface between the MSC and the IM\_MSC (GLh-interface)

This interface is used to forward short messages in the network with the GLR in case of SMS transfer over non-GPRS. Also this interface is used to exchange data needed by the MSC to perform subscriber authorization and allocate network resources. Signalling on this interface uses the Mobile Application Part (MAP) (see TS 29.002 [26]).

## A.5.9 Interface between the GMLC and the IM\_MSC (GLi-interface)

Also this interface is used to exchange data needed by the MSC to perform subscriber authorization and allocate network resources. Signalling on this interface uses the Mobile Application Part (MAP) (see TS 29.002 [26]).

The GMLC regards the IM\_MSC as the MSC via this interface.

## A.5.10 Interface between the GGSN and the IM\_GSN (GLj-interface)

In the network with the GLR when receiving a PDP PDU from the external network the GGSN sends a notification to the IM\_GSN by the routing information from the HLR (see TS 29.060 [51]). The GGSN regards the IM\_GSN as the SGSN via this interface.

## A.5.11 Interface between the SGSN and the IM\_GSN (GLk-interface)

In the network with the GLR when receiving a PDP notification from the GGSN, the IM\_GSN relays the notification to the SGSN by the routing information from the GLR (see TS 29.060 [51]). The SGSN regards the IM\_GSN as the GGSN via this interface.



